

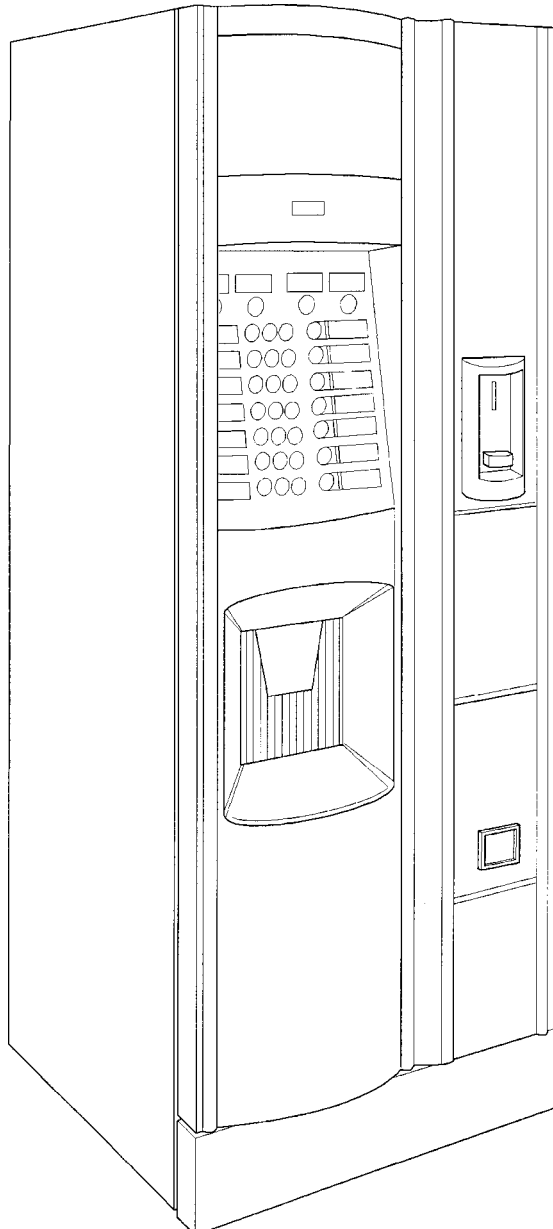

**Automatic drink vending machine**

**model**

# **Saeco Group 500**



**INSTRUCTION AND MAINTENANCE MANUAL**

## CONFORMITY DECLARATION

We:

**SAECO International Group**  
Via Panigali, 39  
40041 GAGGIO MONTANO (BO)

*hereby declare to our own liability that the following product:*

**HOT BEVERAGE VENDING MACHINE**

TYPE: D.A. GROUP 500

To which the present declaration refers is in compliance with the following norms:

- Machinery safety – Fundamental concepts, main design principles.  
Terminology, basic methodology EN 292 part 1 – September 1991
- Machinery safety – Fundamental concepts, main design principles.  
Technical specifications and principles EN 292 part 2 – September 1991
- Electrical household appliance and electrical appliance safety – General requirements EN 60335-1 June 1988 +  
Amendments 2,5,6,A51
- Electrical household appliance and electrical appliance safety – Part 2 –  
Specific requirements of liquid heating appliances  
EN 60335-2-15 – November 1990
- Electrical household appliance and electrical appliance safety – Part 2 –  
Specific requirements for nozzles and coffee grinders  
EN 60335-2-33 – April 1990
- Electrical household appliance and electrical appliance safety – Part 2 –  
Specific requirements for distributors and vending machines  
IEC 335-2-75 – Document
- Limits and measurement methods of radio disturbance generated by electric and thermal motors for domestic and  
related use, electrical instruments and the like  
Electrical appliances – EN 55014 – Ed. 1993
- Electromagnetic compatibility (EMC)  
Part 3 – Limits – Section 2: harmonic current emission limits (appliance input power  $\pm 16A$  for phase) -  
EN 61000-3-2 – Ed. 1993
- Electromagnetic compatibility (EMC)  
Part 3 – Limits –Section 3: Limitation of current fluctuations and peaks in low tension power supply systems for  
appliances with rated current of  $\pm 16A$  - EN 61000-3-3 – Ed. 1994
- Immunity requirements for household electrical appliances, musical instruments and the like.  
Norm for product family – EN 55104 – Ed. 1995

According to the provisions of the following directives:

CE 73/23 - CE 89/392 - CE 89/336 - CE 91/368  
CE 92/31 - CE 93/44 - CE 93/68

The Sole Director: Sergio Zappella



**BEFORE USING THE MACHINE, READ THIS MANUAL CAREFULLY SO AS TO OPERATE IN ACCORDANCE WITH CURRENT SAFETY STANDARDS.**



**ATTENTION: Important safety indications**



**READ the instruction manual carefully before using the machine**

The machine must be disconnected from the mains before any service or maintenance may be carried out



**ATTENTION: machine switched on**

**ATTENTION: hot parts in contact!**

# CONTENTS

1 -	INTRODUCTION .....	4	9 -	MAINTENANCE AND INACTIVITY .....	39
1.1	User instructions .....	4	9.1	Cleaning and Loading .....	39
1.2	General instructions .....	4	9.1.1	Daily cleaning .....	39
2 -	TECHNICAL SPECIFICATIONS ..	6	9.1.2	Weekly cleaning .....	40
3 -	GENERAL TECHNICAL DESCRIPTION .....	7	9.1.3	Product loading .....	41
3.1	Machine description .....	7	9.2	Maintenance .....	41
3.2	Permitted use .....	7	9.2.1	Ordinary and extraordinary maintenance .....	42
3.3	Models .....	7	9.2.2	Coffee unit maintenance .....	42
3.4	Basic operating concepts .....	8	9.3	Settings .....	43
4 -	VENDING MACHINE HANDLING	11	9.3.1	Dosage and grinding regulation .....	43
4.1	Handling and transport .....	11	9.4	Resin regeneration (where the water softener is provided) .....	44
4.2	Storage .....	12	9.5	Inactivity .....	45
4.3	Packaging .....	12	10 -	DISMANTLING .....	46
4.4	Receipt .....	12	11-	TROUBLESHOOTING GUIDE FOR THE MOST COMMON FAILURES OR ERRORS .....	47
4.5	Unpacking .....	13			
5 -	SAFETY STANDARDS .....	14			
6 -	INSTALLATION .....	15			
6.1	Positioning .....	15			
6.2	Water mains connection .....	16			
6.3	Electric mains connection .....	17			
6.4	Machine start-up .....	18			
6.5	Installation .....	19			
6.5.1	Cleansing of resin-based water softener (available as a kit) .....	19			
6.5.2	Water circuit filling .....	20			
6.5.3	Cleaning the parts in contact with foodstuffs .....	21			
6.6	Product loading .....	22			
6.6.1	Container loading .....	22			
6.6.2	Label insertion .....	23			
6.6.3	Cup loading .....	24			
6.6.4	Spoon loading .....	25			
6.6.5	Coffee grounds bag insertion .....	26			
6.6.6	Payment system installation .....	27			
7 -	PROGRAMMING .....	28			
7.1	Function description .....	32			
8 -	SERVICE .....	37			

# 1 - INTRODUCTION

## 1.1 User instructions

This vending machine is safe for all those who follow the loading and ordinary cleaning instructions given in this manual.



### Caution

For no reason whatsoever must the operator access those parts of the machine that are protected by guards requiring special instruments for their removal.

Some maintenance operations (to be carried out solely by specialised technicians) expressly require that certain safety devices are switched off.

Acquaintance and absolute respect, from a technical point of view, of the safety standards and danger warnings contained in this manual, are fundamental for installing, using and servicing the machine under conditions of minimum risk.

## 1.2 General instructions



*Before using the vending machine, read this manual carefully.*

*Knowledge of the information and instructions contained in this document is essential for a correct use of the vending machine by the user.*

- Measures carried out by the user on the automatic vending machine are allowed only if they are his responsibility and if he has been duly trained.  
The user must be fully acquainted with all operating mechanisms of the machine as far as it falls within his competence.

- It is the buyer's responsibility to ascertain that the users have been trained and informed of all the indications and specifications contained in the documentation supplied. Even so, the operator or the user must be aware of the potential risks that exist while operating the automatic vending machine.
- This manual is an integral part of the equipment and as a consequence must always be kept inside or nearby the machine so as to allow easy consultation by the various operators until the machine is dismantled and/or scrapped.
- In the event of loss or damage of this manual, it is possible to request a new copy from the manufacturer, indicating the data registered on the machine serial number label.
- Operating reliability and the efficiency of the machine's performance are guaranteed only if original parts are used.
- The user will be held entirely responsible for any modifications he may make to the machine.  
All the operations necessary in order to maintain the machine in working order, before and during use, are to the charge of the user.
- Tampering with or modifications made to the machine not previously authorized by the manufacturer, release the latter from any liability for damage deriving from, or referable to the above mentioned modifications.
- This manual reflects the status of the automatic vending machine at the moment of the issue on the market; possible modifications, up-grades or adjustments that are made to machines that are marketed subsequently, do not oblige the SAECO International Group either to intervene on the machine previously supplied or consider it and the relevant manual to be defective or inadequate.

- However, the *SAECO International Group* is entitled, when it deems it expedient for valid motives, to up-date the manuals already present on the market and send revised information sheets to their customers which must kept together with the original manual. Any technical problems that may arise can be solved easily by consulting this manual. For further information, contact the dealer where the machine was purchased, or one of the authorised service centres.

When calling please, give the following information:

- The data registered on the serial number label (fig. 1);
- The version of program resident in the microprocessor (see the adhesive label on the component mounted on the C.P.U. card (ref. 1, fig. 2) or, if possible, the version of program shown on the machine display when button 2 is pressed on the CPU card to activate the "Service" mode (fig. 42).
- The card code appearing on the welded side of the C.P.U. board.

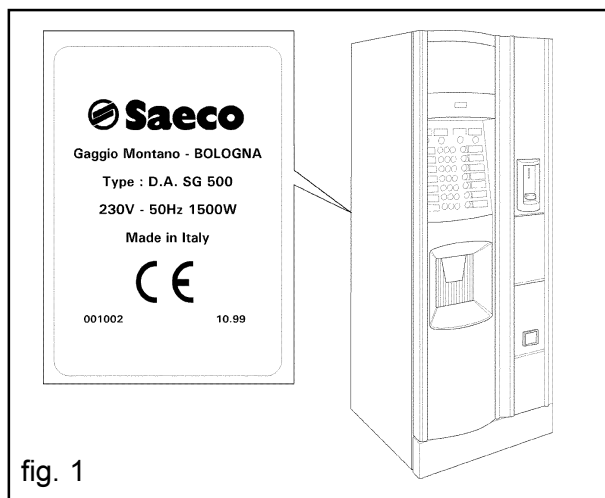

fig. 1

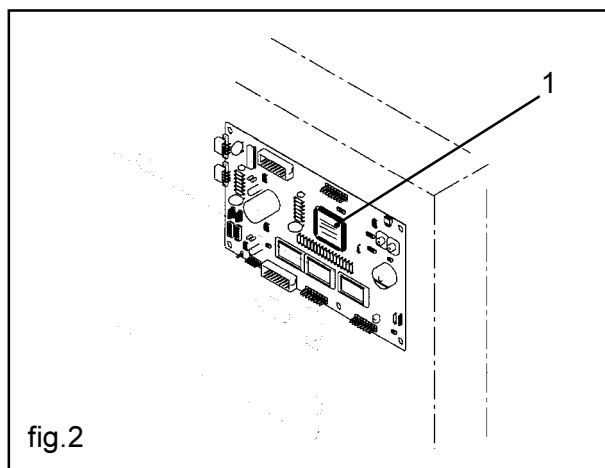

fig.2

The SAECO International Group declines all responsibility for damage caused to persons or property as a consequence of:

- Incorrect installation
  - Inappropriate electrical and/or water connection
  - Inadequate cleaning and maintenance
  - Unauthorised modifications
  - Improper use of the distributor
  - Non-original spare parts
- In no event will the *SAECO International Group* be obliged to indemnify any damages caused as a result of the forced inactivity of the machine due to failure.
  - Installation and maintenance operations must be carried out exclusively by qualified engineers.
  - Use only specific foodstuffs for use in automatic vending machines.
  - The automatic vending machine is not suitable for outside installation. The machine must be installed in dry locations, with temperatures of no lower than 1°C and it must not be installed in places where cleaning is done with water hoses (e.g. large kitchens ...).
  - If at the time of installation, the usage conditions are different from those established or are subject to change over time, please contact the manufacturer immediately before using the machine. Furthermore always act in compliance with national or local standards.

## 2 - TECHNICAL SPECIFICATIONS

Height	mm	1,700
Width	mm	590
Depth	mm	674
Weight		from Kg 90 to Kg 105

Power supply voltage	Volts	230
Power Frequency	Hz.	50
Installed power	KW	1.50

Water mains connection	3/8 gas
Electric mains connection	SCHUCO plug

### BOILER RESISTANCES

Armour-plated type:  
1000 Watt for coffee boiler

### CONTAINER CAPACITY

Coffee in grains	Kg	4.0
Instant coffee	Kg	1.5
Powdered milk	Kg	2.1
Chocolate	Kg	4.3
Tea	Kg	5.9
Soup	Kg	5.5
Sugar	Kg	5.6
Cups		500
Spoons		500

### WATER SUPPLY

From mains with pressure between 0.5 and 6.5 bar

### CUP DISPENSER

Suitable for cups with diameter mm 70-71

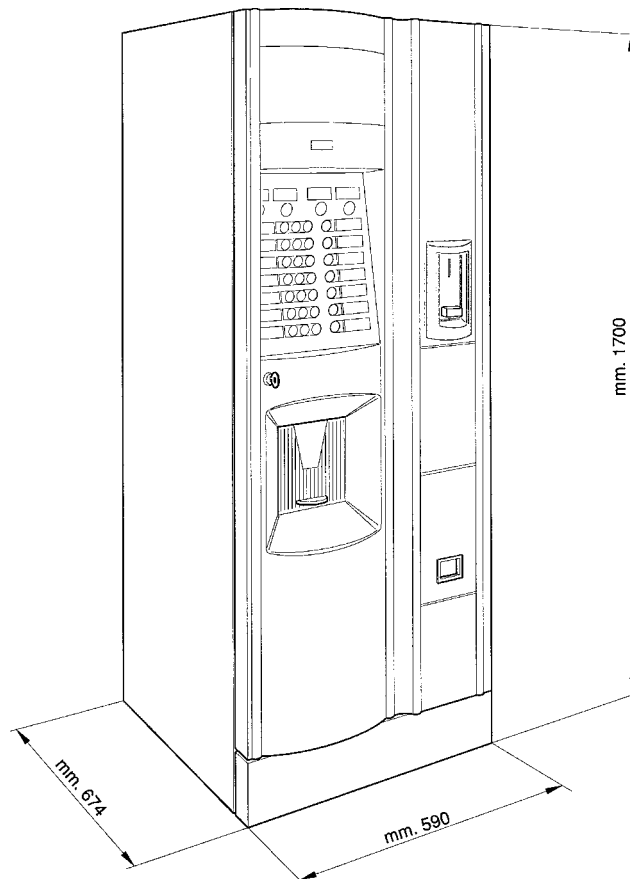

fig.3

## 3 - GENERAL TECHNICAL DESCRIPTION

### 3.1 Machine description

(fig. 4)

- ref.1 Coffee unit and grinder
- ref.2 Drinks distributor unit
- ref.3 Sugar dispenser unit
- ref.4 Electronic board
- ref.5 Cup dispenser
- ref.6 Coin box unit

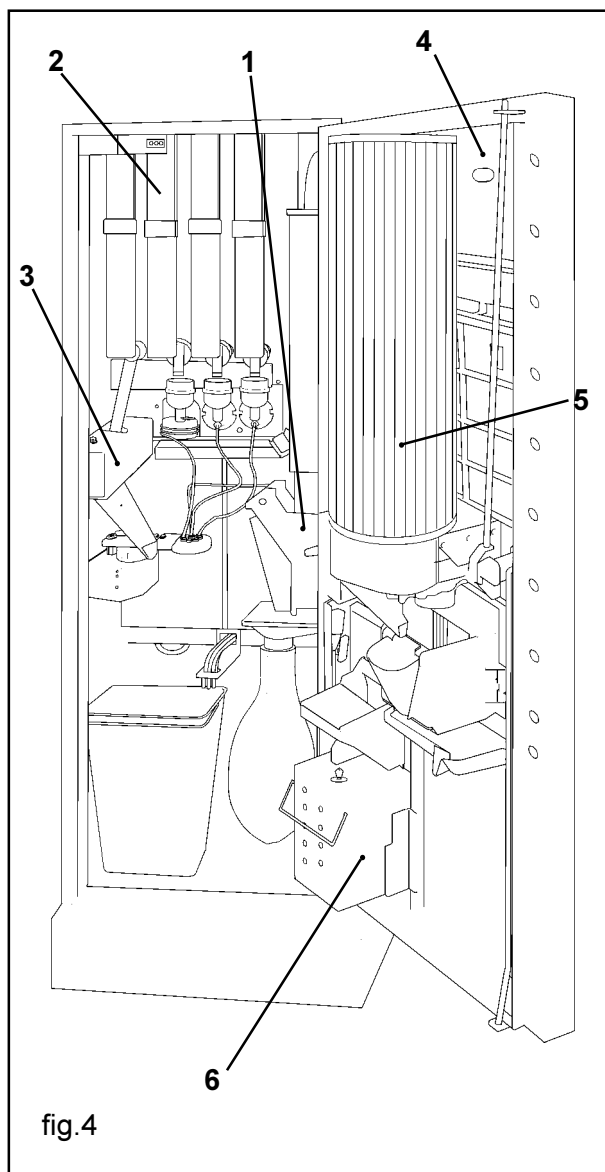

fig.4

### 3.2 Permitted use

The distributor is to be used exclusively for the dispensing of drinks, prepared mixing foodstuffs with water (by infusion as far as coffee is concerned).

For this purpose, use products that the manufacturer has declared suitable for the automatic distribution in open containers.

The drinks are dispensed into specific plastic cups automatically distributed by the machine. The sugar stirring spoon is dispensed automatically.

The drinks must be consumed immediately and under no circumstances must they be kept for subsequent consumption.

### 3.3 Models

The following terminology is used so as to distinguish the various models of automatic distributors:

**SAECO GROUP 500 Standard**

Version with plastic coffee unit and 3 instant products

**SAECO GROUP 500 FREEZE DRIED**

Version with plastic coffee unit and freeze dried coffee drink instead of freeze dried tea

#### Attention

*This manual refers to the top-of-the -range model:*

*it is therefore possible to find descriptions or explanations not relating to your machine.*

### 3.4 Basic operating concepts

During normal functioning, the distributor is in standby status. By introducing the necessary amount, according to the pre-set price, and pressing the key relating to the desired drink, the drink dispensing cycle is activated: It can be divided in different processes:

#### CUP DISPENSING

- This is the first operation that the distributor activates (except for "without CUP" dispensing).
- The motor that operates the nozzle support is activated in order to move the support back and let the cup drop into the delivery receptacle. (fig. 5).

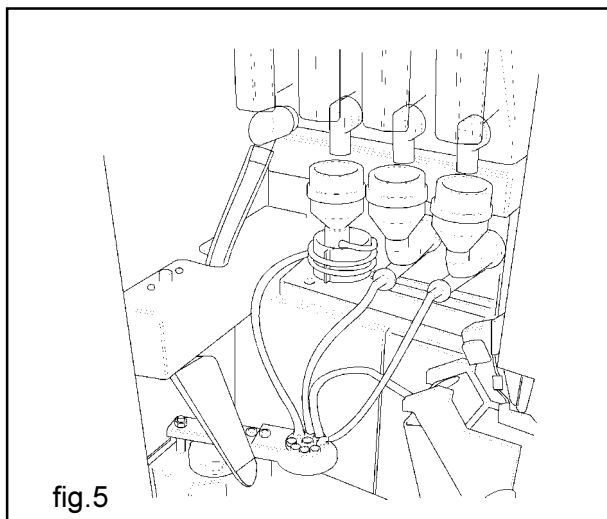

- The motor inside the cup dispenser moves the scrolls in order to separate and make the cup fall into the special support fork inside the delivery receptacle (fig.6).

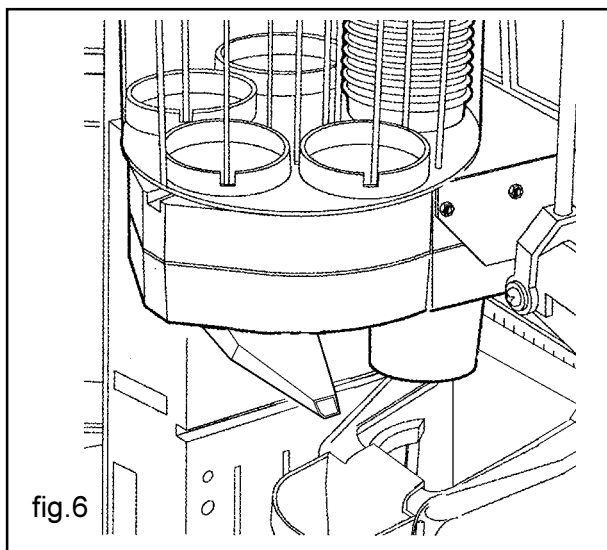

#### SUGAR AND SPOON DISPENSING

Where anticipated and requested, a maximum set amount of sugar is dispensed with the possibility to stop when the desired dose has been achieved.

The dispensing procedure occurs according to the following stages:

- The drive motor of the chute which conveys the sugar into the cup is activated (fig.8).

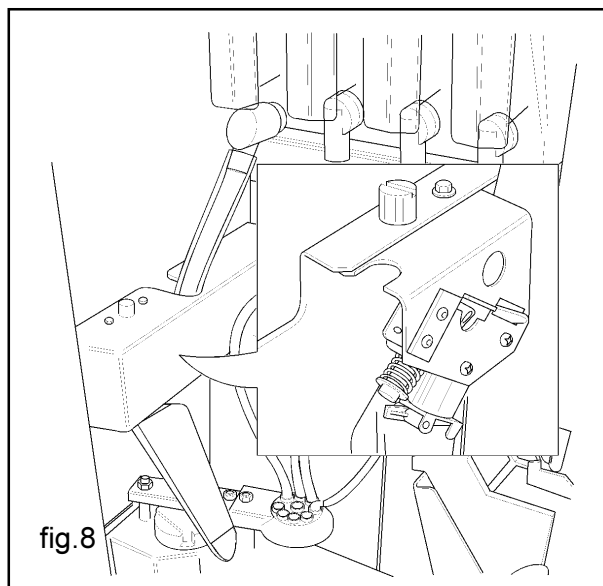

- The gear motor activates the helicoidal screw conveyor of the sugar container, dispensing the desired quantity into the product chute (fig.7).

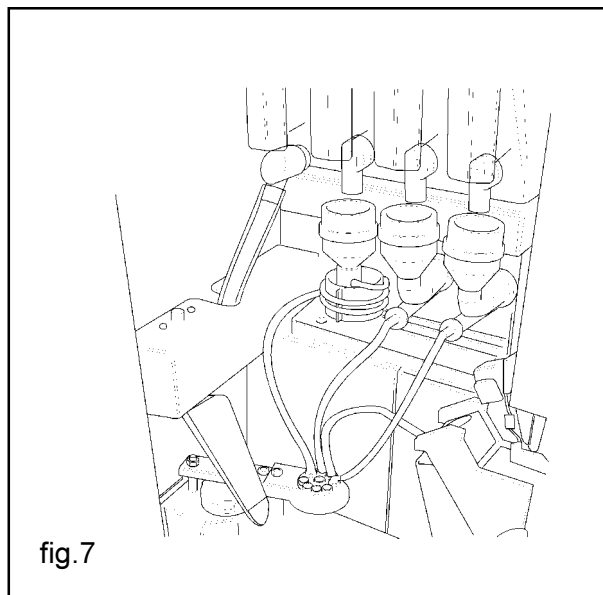

- The electromagnet that controls the spoon is engaged and the spoon is delivered directly into the cup through the appropriate chute (fig.9).

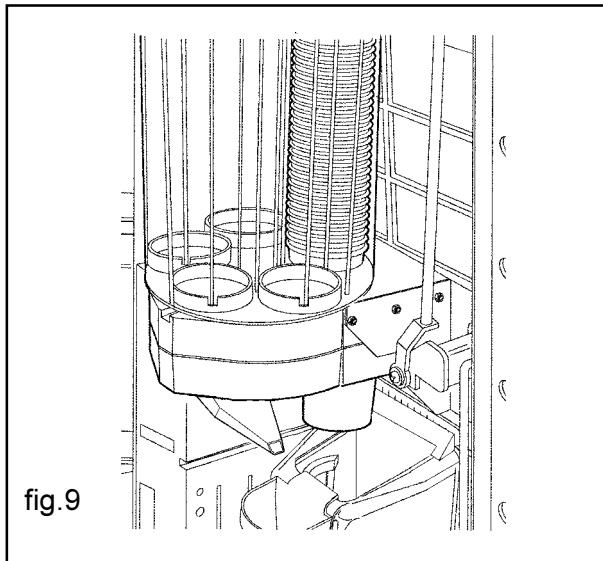

### INSTANT DRINKS

This process is activated after the processing of cup, sugar and spoon dispensing has been completed.

According to the drink type requested and distributor model, the processes described below are activated for the preparation of the drink.

- If present, the motor-mixer is activated (fig.10).

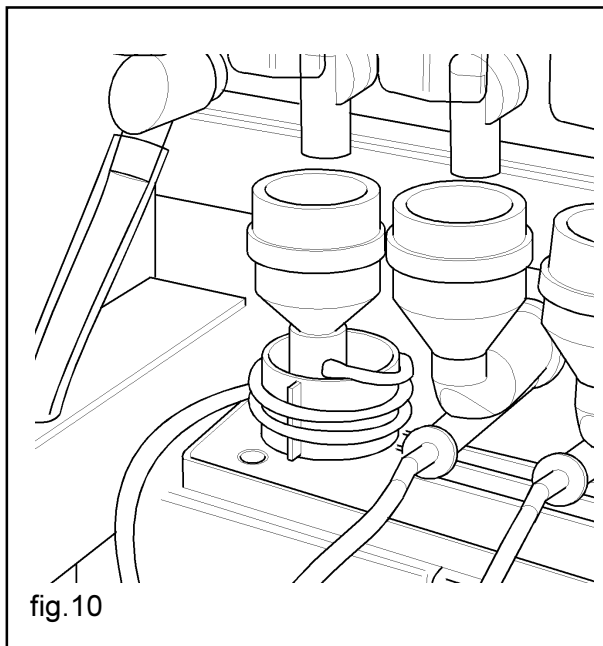

- The solenoid valve for instant drinks, fixed to the coffee boiler, is engaged in order to deliver the required quantity of water into the mixer (fig.11); the pump that delivers the required amount of water - controlled by a special electronic device (volumetric counter)- starts up.

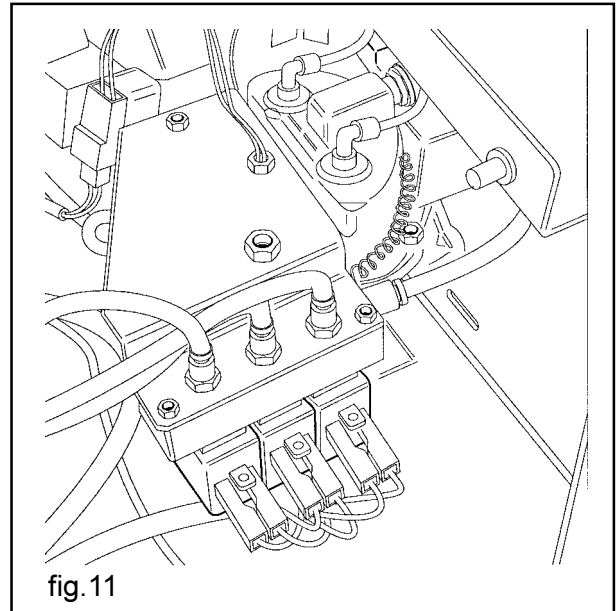

- The instant product gear motor activates the helicoidal screw conveyor so as to dispense the programmed quantity of product into the mixer (fig. 12).

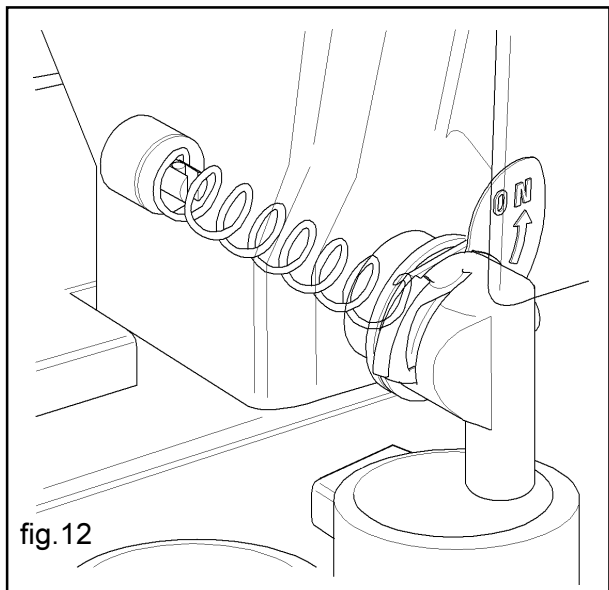

fig. 12

- Once the pre-set quantity of water and powder is dispensed, the motor-mixer is switched off.

### ESPRESSO COFFEE

This process occurs after dispensing cup, sugar and spoon.

- The grinder is activated until it produces the dose of ground coffee set by the doser (fig. 13).

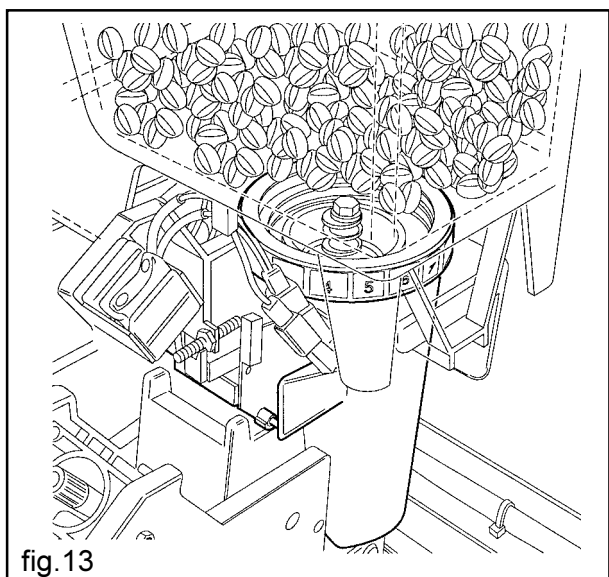
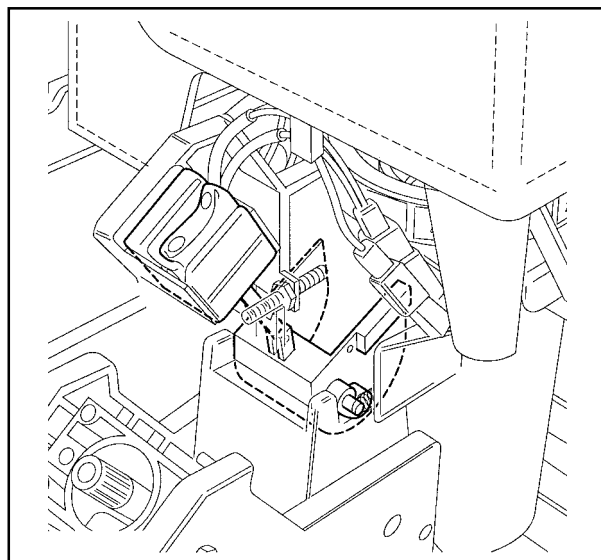

fig. 13

- The doser electromagnet is activated, causing the opening of the door and the consequent drop of the coffee into the brew chamber (fig. 14).



- The rotation unit gear motor starts-up, brings it into the dispensing position and simultaneously compresses the ground coffee (fig. 15).

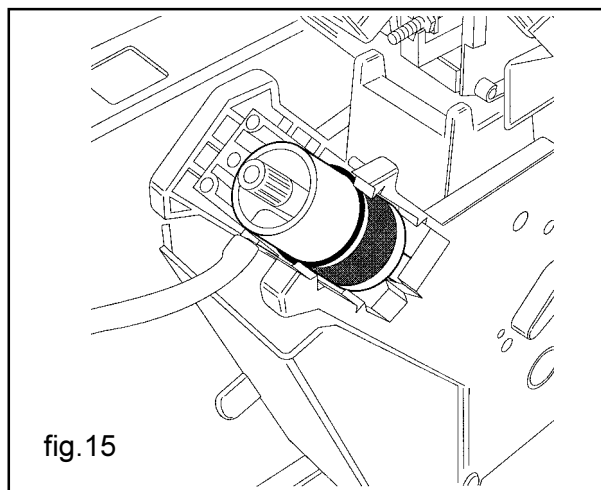

fig. 15

- The pump that delivers the required amount of water -controlled by a special electronic device (volumetric counter)- starts up, withdrawing the water from the coffee boiler (fig. 16).

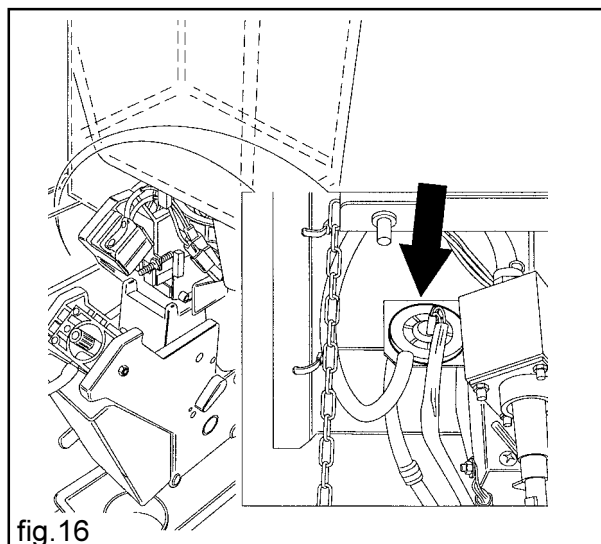

fig. 16

- The coffee unit gear motor is activated again so as to return to the standby position; during this movement the coffee grounds are expelled (fig.17).

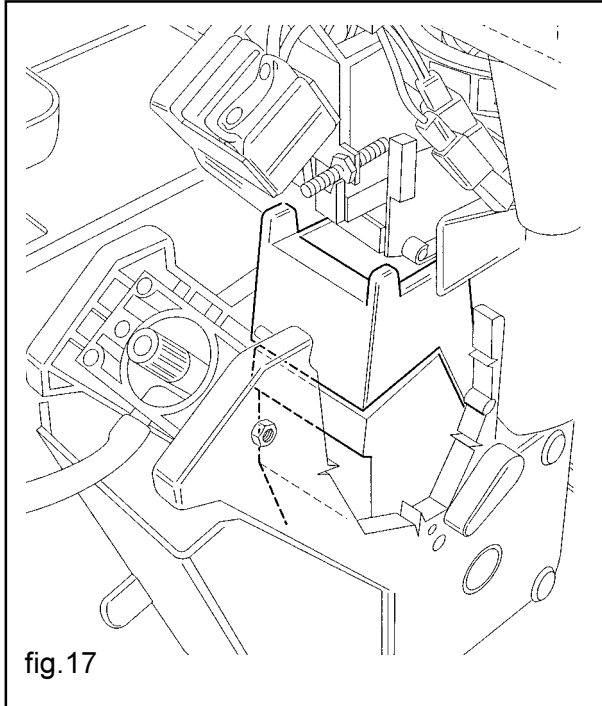

fig.17

The activation sequence of grinder and coffee doser can be inverted depending on the pre-set programming type (see programming menu).

## 4 - VENDING MACHINE HANDLING

### 4.1 Handling and transport

(fig. 18)

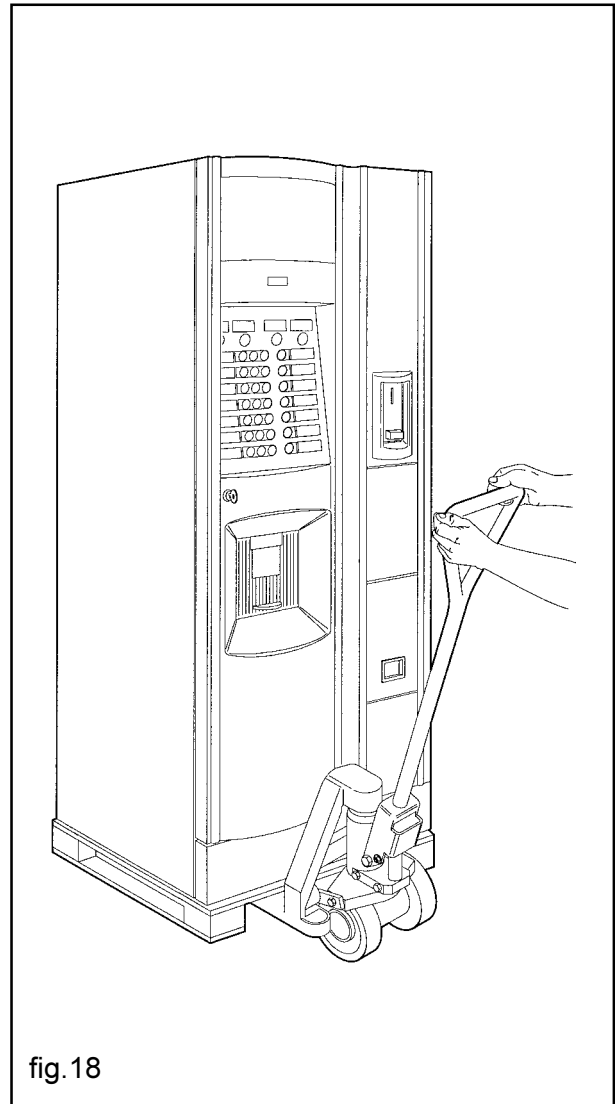

fig.18

The transport of the distributor must be carried out by competent personnel.

The distributor is delivered on a pallet; for handling purposes use a pallet truck and move it slowly in order to avoid capsizing or dangerous movements.



### Attention

Avoid :

- lifting the distributor with ropes or presses
- dragging the distributor
- turning over or laying the distributor down during transport;
- jolting the distributor

With regard to the distributor, avoid :

- bumping it
- overloading it with other packages
- exposing it to rain, freezing weather or sources of heat
- keeping it in damp places

### 4.2 Storage

In the event of storage, avoid placing several machines one on top of another, maintain it in a vertical position, in dry places with temperatures of no lower than 1° C.

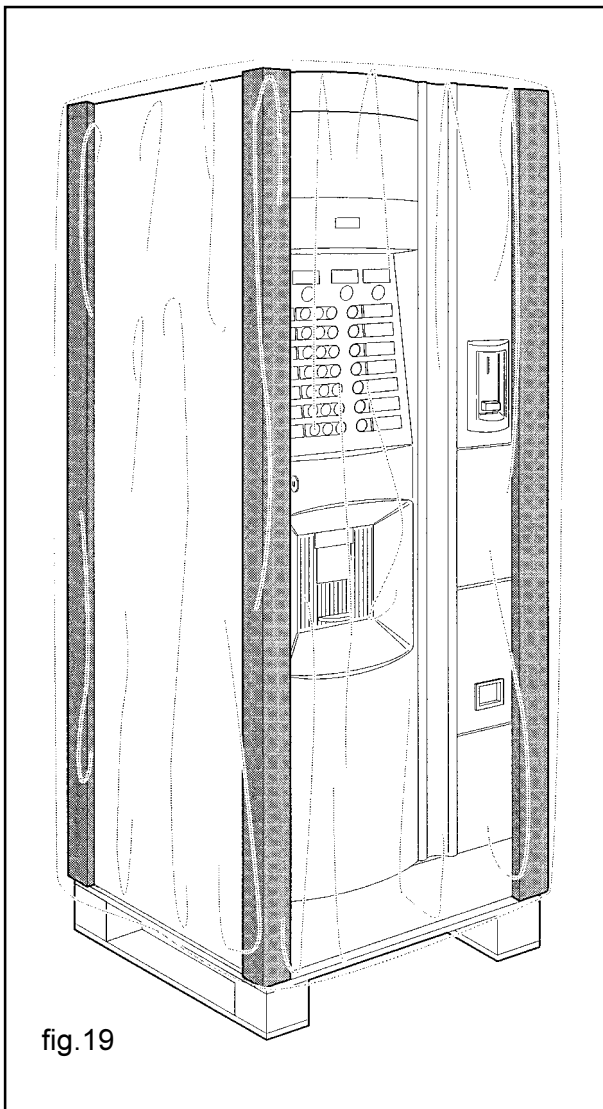

fig. 19

### 4.3 Packaging

The distributor is protected by polystyrene angles and by a transparent polypropylene film (fig. 19).

The automatic distributor will be delivered packaged, assuring both a mechanical guard and protection against damage from the outside environment.

Labels are applied on the packaging, indicating:

- handle with care;
- do not turn upside-down;
- protect from the rain;
- do not place one on top of another;
- protect from sources of heat;
- not bump resistant;
- type of distributor and serial number.

### 4.4 Receipt

Upon receipt of the automatic distributor, it is necessary to check it has not suffered damage during transport. If damage of any kind is noticed, place a claim with the forwarder immediately.



### Attention

*On conclusion of transport, the packaging must be integral which means it must not:*

- present dents, signs of bumps, distortions or breakages to the external packaging;
- present wet zones or signs that could lead one to suppose that the packaging has been exposed to rain, freezing weather or heat;
- present signs of tampering.

### 4.5 Unpacking

- Free the distributor from the packaging, cutting the protective film in which it is wrapped, along one of the protection angles (fig.20).

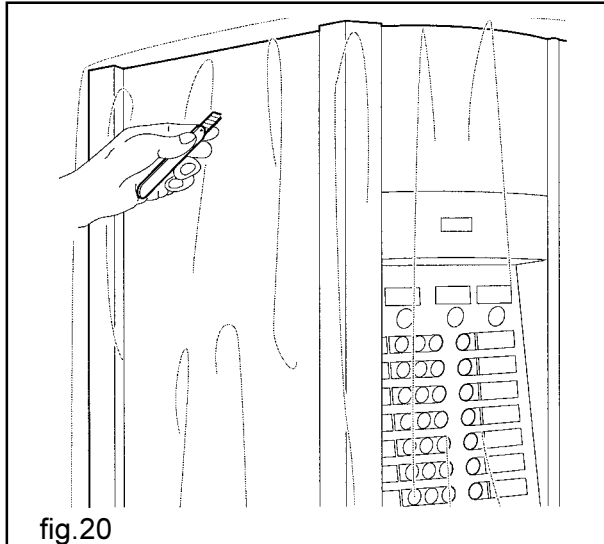

Remove the distributor from the transport pallet, unscrewing the screws that secure it to the pallet (fig.21).

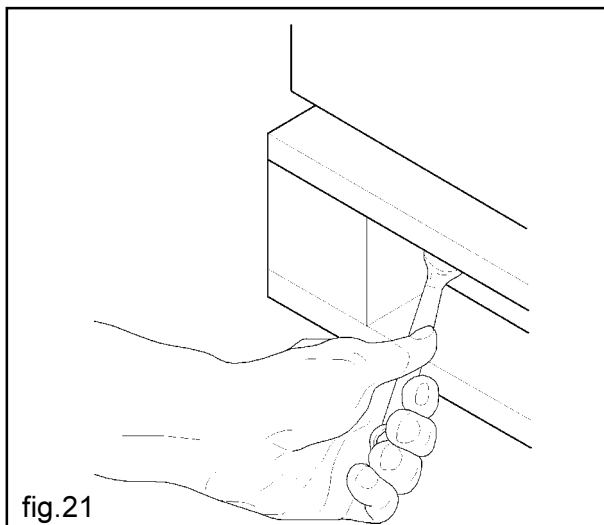

- Remove the key from the drink dispenser receptacle (fig.22).

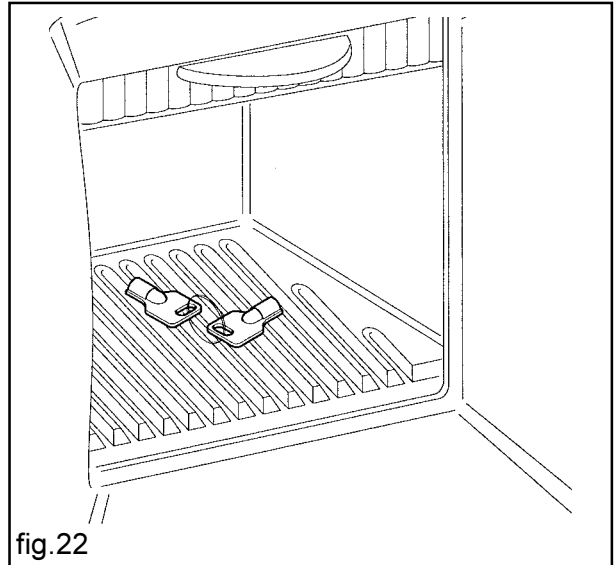

Open the door of the distributor and remove the adhesive tape from the components, listed below:

- cup dispenser (example in fig.23)
- coin box
- coffee unit, coffee chute
- spoon dispenser counter-weight
- product containers
- liquid waste float mechanism
- bottom skirting-board
- liquid waste bin.

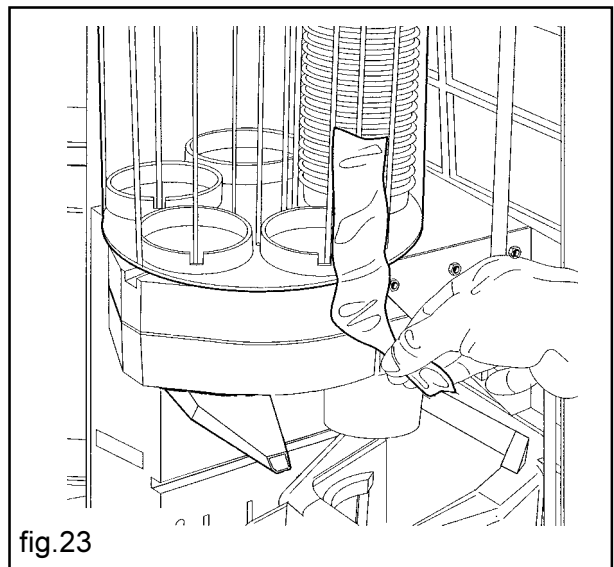

- remove the polystyrene that blocks the product containers (fig.24)

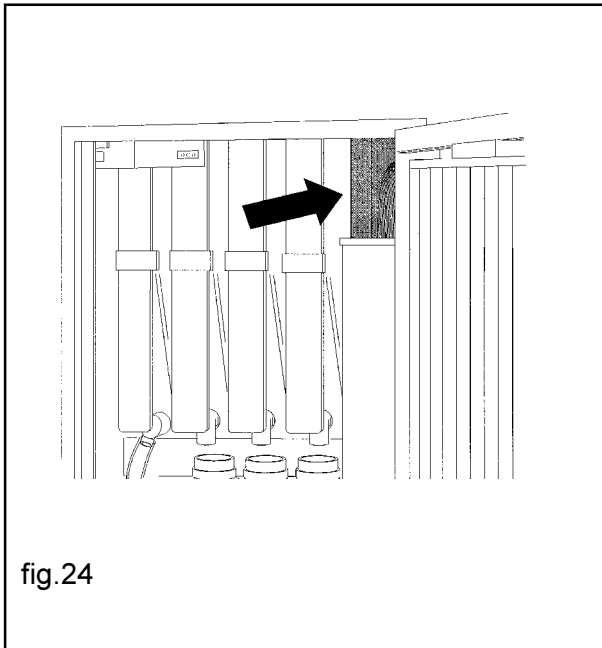

### Caution

*The packing material must not be left accessible to others, as it is a potential source of danger. For the disposal contact qualified companies.*

## 5 - SAFETY STANDARDS



- Before using the automatic distributor, read this manual carefully.
- The installation and maintenance operations must be performed exclusively by qualified technical personnel.
- For no reason whatsoever must the operator access those parts of the machine that are protected by guards requiring special instruments for their removal.
- Acquaintance and absolute respect, from a technical point of view, of the safety standards and danger warnings contained in this manual, are fundamental for installing, using and servicing the machine in conditions of minimum risk.

Always disconnect the POWER CABLE before maintenance or cleaning activities.

Do not, under any circumstances, intervene on the machine or remove safety guards before hot parts have cooled!

- Operating reliability and the efficiency of the machine's performance are guaranteed only if original parts are used.
- The automatic vending machine is not suitable for outside installation. The machine must be installed in dry locations, with temperatures of no lower than 1°C and it must not be installed in places where cleaning is done with water hoses (e.g. large kitchens ...).
- In order to guarantee regular functioning, always maintain the automatic distributor under perfect cleaning conditions.

- the SAECO International Group declines all responsibility for damage caused to persons or property as a consequence of:
  - Incorrect installation
  - Inappropriate electrical and/or water connection
  - Inadequate cleaning and maintenance
  - Unauthorised modification
  - Improper use of the distributor
  - Non-original spare parts
- Furthermore you are advised to always act in compliance with national or local standards.

## 6 - INSTALLATION

### 6.1 Positioning

The automatic vending machine is not suitable for outside installation. The machine must be installed in dry locations, with temperatures of no lower than 1°C ; furthermore, it must not be installed in places where cleaning is done with water hoses or in places where there is danger of explosions or fires.

- If positioned near a wall, there must be a minimum distance from the wall of at least 5 cm. (fig.25) so as to allow regular ventilation. Under no circumstances cover the distributor with cloths or similar.

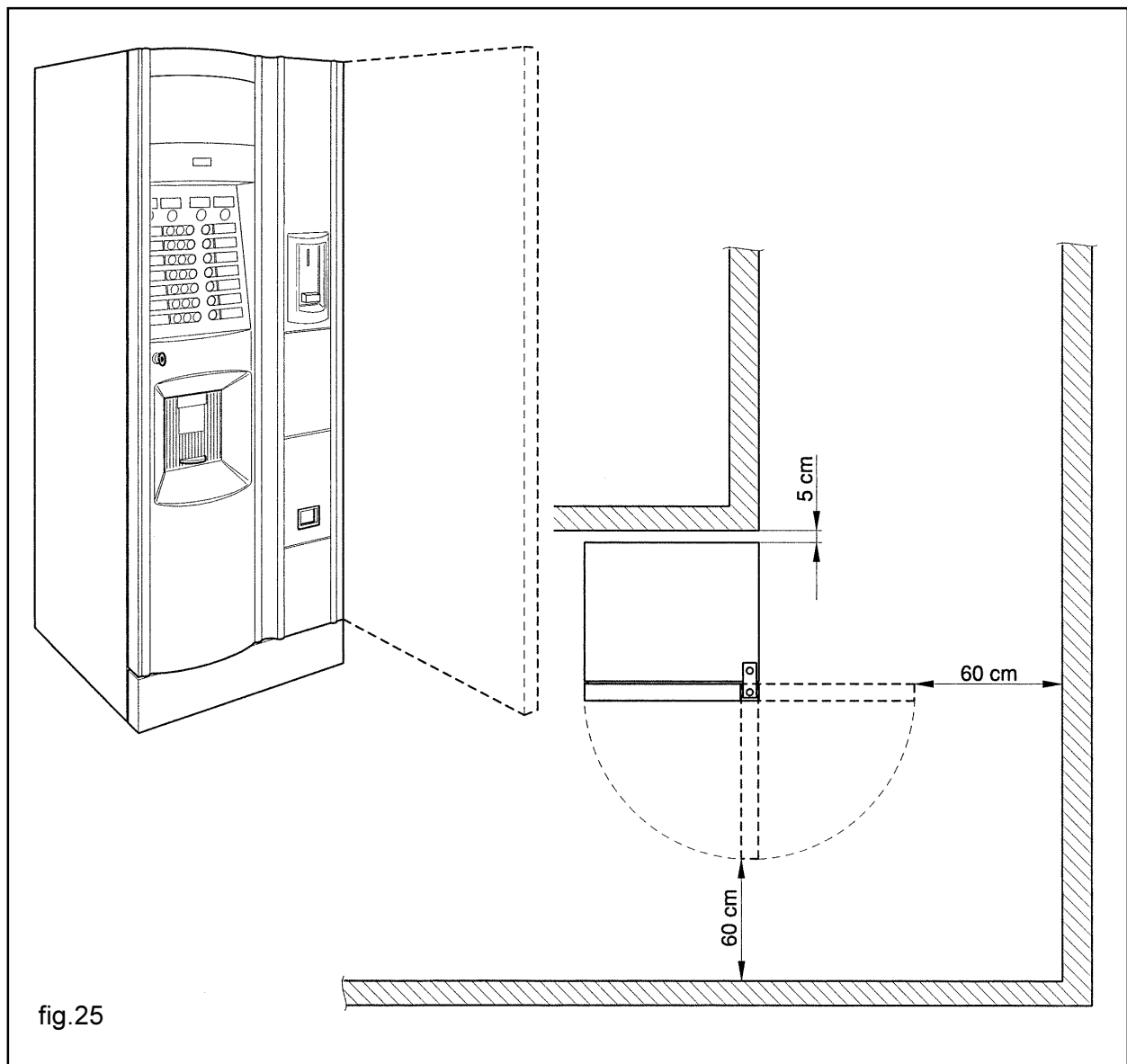

- Position the distributor, checking the levelling by means of the adjustable feet already assembled on the machine (fig.26). Make sure that the distributor does not have an inclination of more than 2 degrees.

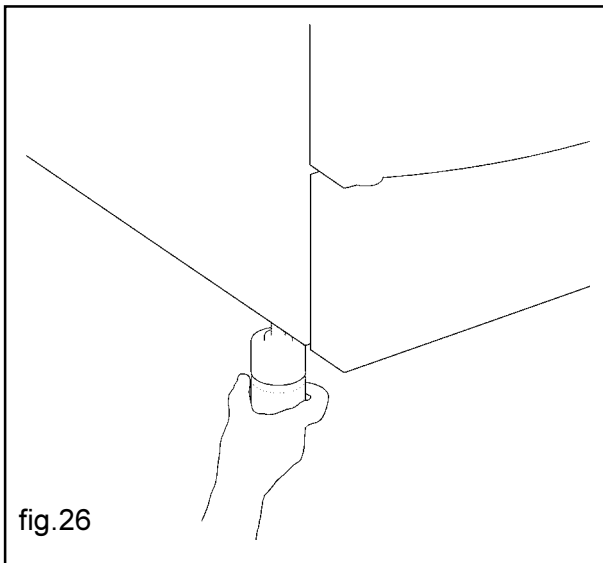

The SAECO International Group declines all responsibility for inconveniences caused as a result of the failure to observe the above mentioned installation norms.

If installation takes place in safety evacuation corridors, make sure that the distributor with the door open leaves sufficient space for individuals to pass by (fig.25).

In order to avoid dirtying the floor as a result of the accidental spillage of products, use, if necessary, a protective matting sufficiently wide to cover the operating area under the distributor.

## 6.2 Water mains connection

Before connecting the distributor to the water mains make sure that the water :

- is drinkable (if necessary by means of test laboratory certification);
- has a pressure ranging between 0.5 bar and 6.5 bar (otherwise use a pump or a water pressure reducer accordingly);
- if not already present, install a tap in an accessible position so as to separate the apparatus from the water mains should it be necessary (fig.27);

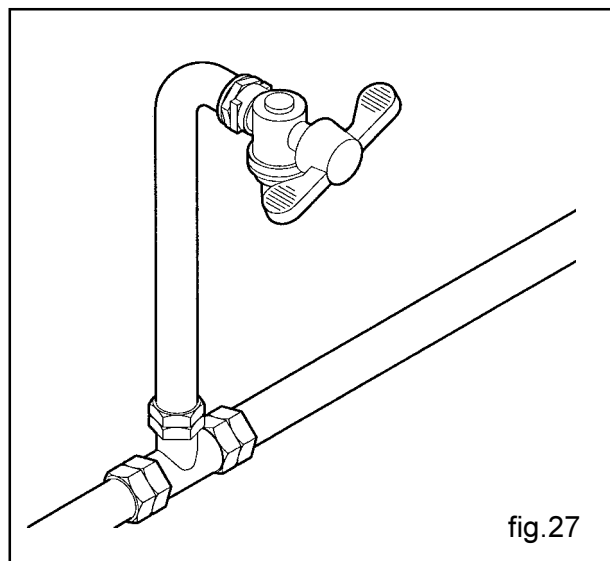

- let some water flow out of the tap so as to eliminate possible traces of impurities and dirt (fig.28);

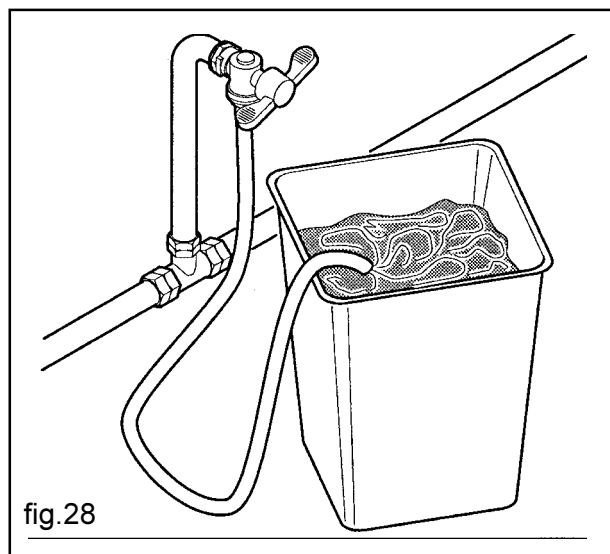

- connect the tap to the distributor, using a rigid copper or nylon pipe, suitable for foodstuffs and adequate for the purpose of bearing the water supply pressure. Should a flexible pipe be used, it is necessary to assemble the reinforcement bearing inside, which comes supplied with the machine (fig.29);

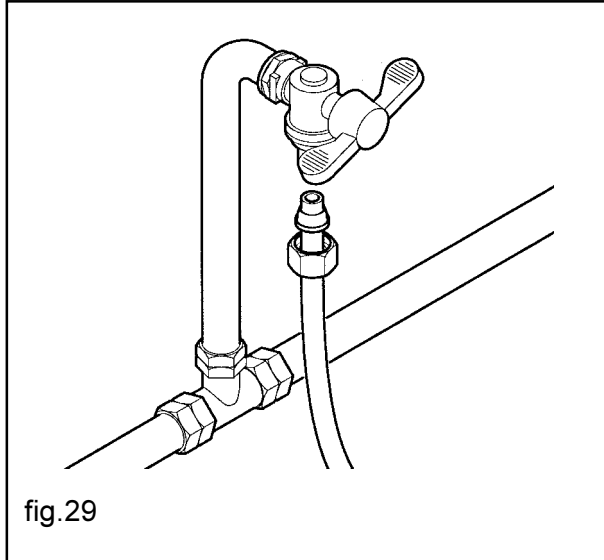

fig.29

- the anticipated connection is a 3/8 gas (Fig.30).

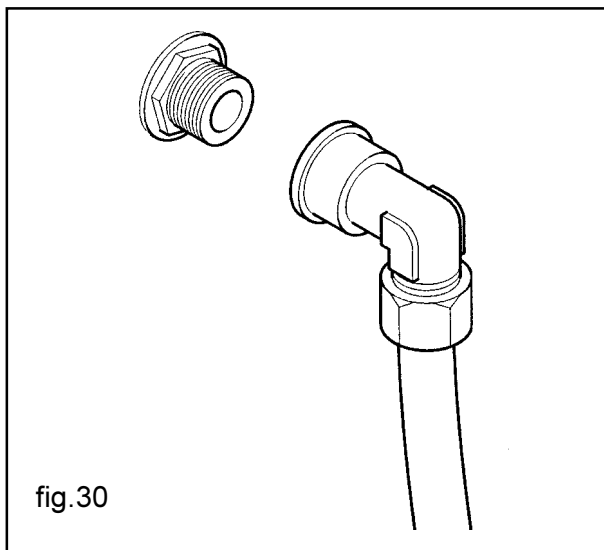

fig.30

### 6.3 Electric Mains connection

The distributor is designed to operate with monophasic 230 Volt voltage and is protected by 10A and 16A fuses.

We suggest that you should check the following:

- the mains voltage of 230 V must not have a difference of more than  $\pm 6\%$ ;
  - the power supply must be adequate to bear the load of the machine;
  - use a diversified protection system.
- The machine must be earthed in observance with operating safety norms.

For this reason, verify the system earth wire connection to ascertain that it is efficient and in compliance with national and European electric safety standards.

If necessary, request the intervention of qualified personnel for the verification of the plant.

- The distributor is equipped with a power supply cable H05VV-F 3x1.5 mm<sup>2</sup>, with a SCHUCO plug (fig.31).

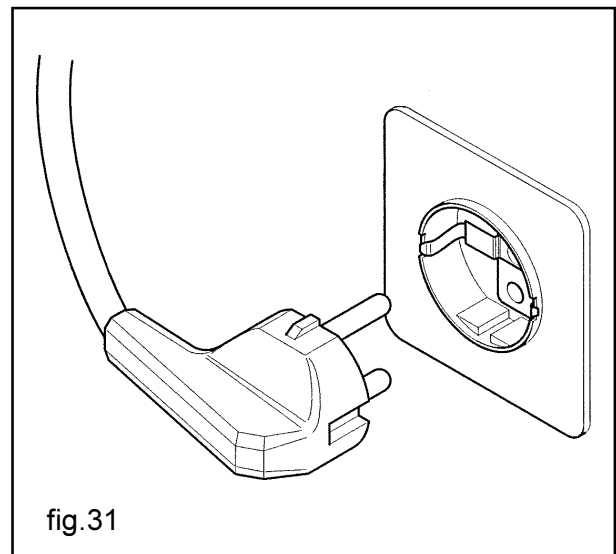
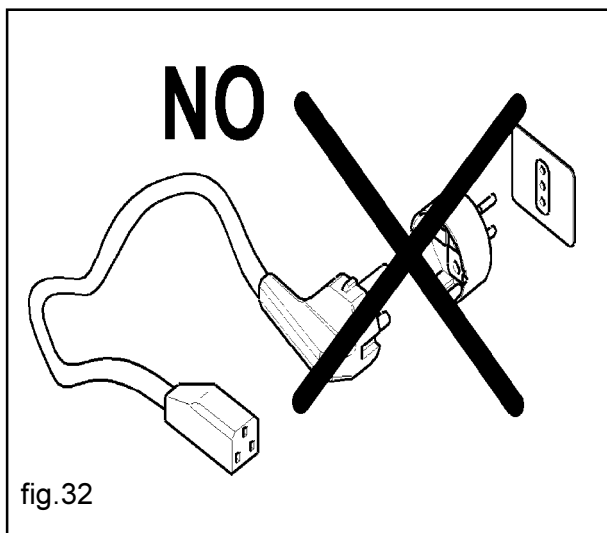

fig.31

- The sockets that are not compatible with the plug of the machine must be replaced.
- The use of extensions, adapters and/or multiple plugs is forbidden (fig.32).



The SAECO International Group declines all responsibility for damage due to the non observance of the aforesaid norms.

#### 6.4 Machine start-up

The distributor is equipped with a safety switch (fig.33) which disconnects the power supply to the machine whenever the door is opened (see electrical layout).

In case of necessity, therefore, open the door or unplug the installation.

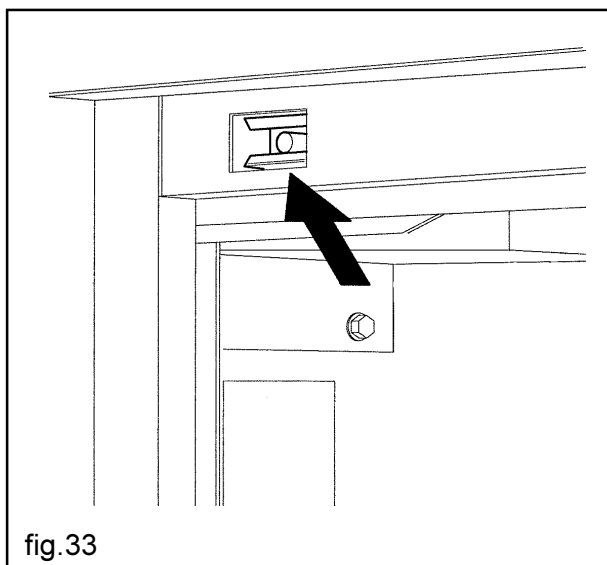

#### Caution

*During the setting-up phase, before powering up the machine, make sure you have connected it to the hydraulic system and opened the water tap.*

#### Caution

*The power cable plug (ref.1, fig.34) as well as the service switch inside the distributor (ref.1, fig. 35) remain live.*

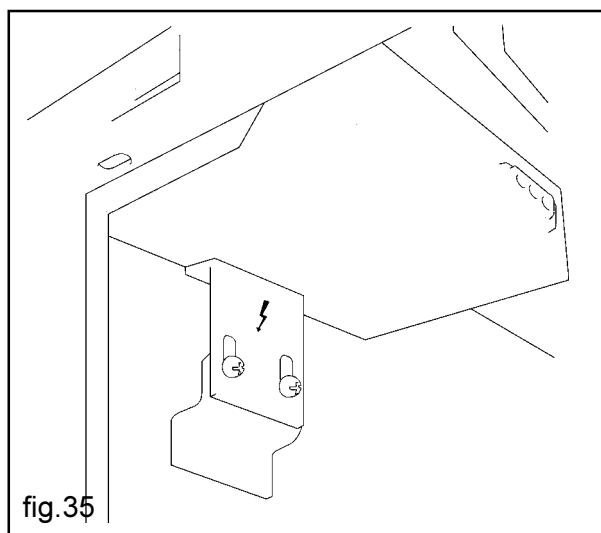
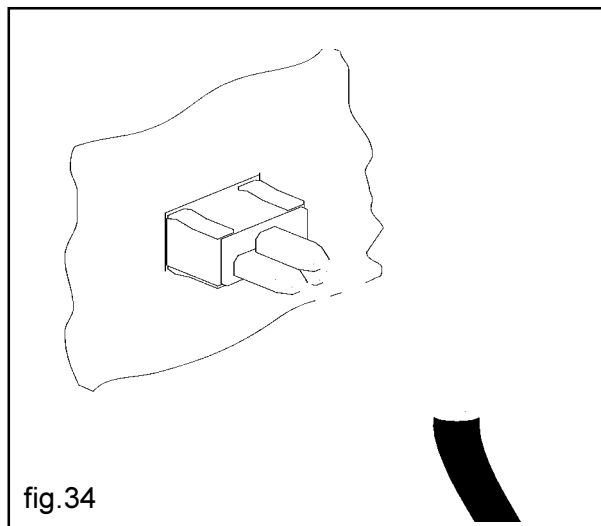

- It is however necessary to operate with the door open but the distributor connected to the mains for some operations.

Competent technicians only may operate in this manner, by inserting the special plastic key, supplied with the distributor, into the door switch, turning it 90° (fig.36).

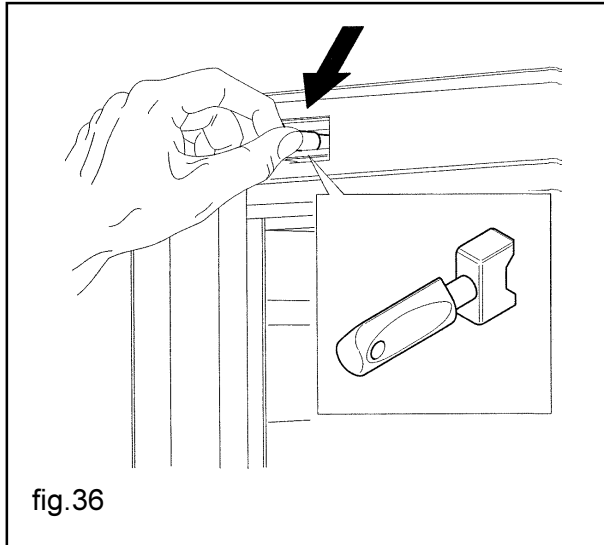

**D Caution**

*The opening and eventual activation of the distributor with the door open (for cleaning purposes only) must only be performed by authorized and technically qualified personnel. Do not leave the distributor unattended while it is open.*

Give the key to qualified personnel only. Each time the distributor is switched on a diagnosis cycle is performed in order to verify the correct position of the moving parts and the presence of water and other products.

**6.5 Installation**



**Important**

*When switched on, the machine automatically proceeds to fill the water circuit and the related boilers. For a correct automatic installation in the event of using a water softener system, it is necessary that the latter is completely filled with water and opportunely relieved of any air bubbles*

**6.5.1 Cleansing and filling of resin-based water softener**

Before installing the water softener in the machine and using it, it is advisable to cleanse the resins and fill the water softener. Therefore, install the water softener already filled with water and cleansed. If you wish to carry out this operation directly in the machine, act as follows:

- Insert the pipe of the bottom tap in a container suitable for this use.
- open the bottom tap (fig.37) and the upper tap of the water softener so as to remove the air bubble.

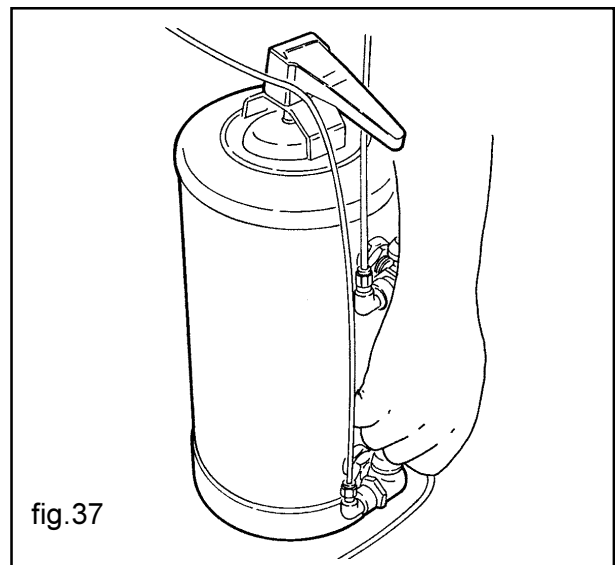

- insert the key in the door switch (fig.38).
- let the water softener fill up completely and remove the key from the door switch.
- close the upper tap.
- insert the key once again in the door switch.

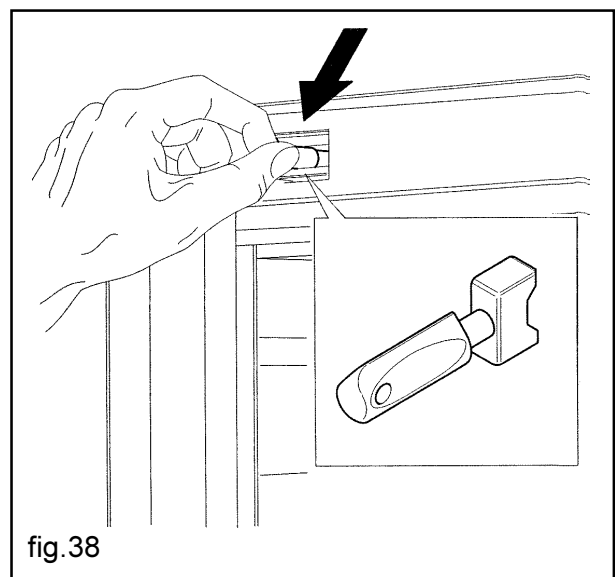

- let the water flow out of the waste pipe until it is clear (fig.39).

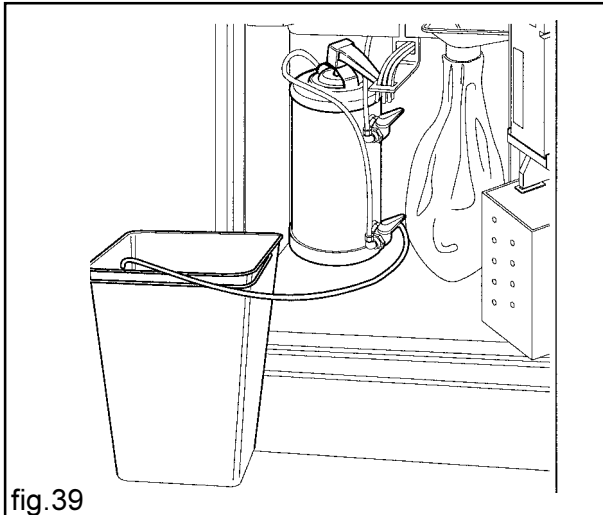

fig.39

- remove the key and close the tap.

### 6.5.2 Water circuit filling

The machine proceeds to fill the instant products boiler first, if present, and the water chamber; subsequently it fills the espresso coffee boiler automatically activating two continual vends of long coffee.

#### Important

*Before switching the machine power on and thus proceeding with the automatic installation:*

1. Ensure that the water softener is filled with water and the air bubbles removed.
2. Load the coffee grains into the appropriate container; this operation is necessary so that the machine automatically dispenses coffee for the purpose of filling the boiler.
3. Load at least the central column of the cup container.

#### NOTE:

If the filling of the boiler is not successful, the machine will not make itself available for service and will indicate "installation failed" on the display panel; in such an event, eliminate the defect and repeat the automatic installation, after having reset the faults (Section 8 – SERVICE, failure reset).

After the DIAGNOSTIC stage the machine automatically fills the hydraulic circuit of the chamber with water float of the instant drinks boiler and of the boiler for the coffee unit. During this stage, the heating resistance of the boiler remains automatically off. If the machine detects that the boiler is loaded, it automatically passes to the HEATING stage.

The sequence of operations will be:

- insert the special key in the door switch;
- on start-up of the machine, the water chamber with float automatically starts to fill up, while the machine carries out the automatic diagnosis stage.

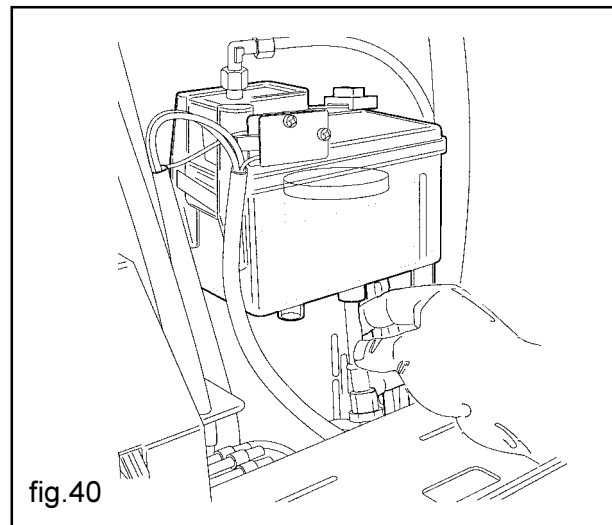

fig.40

#### Important

*Compress the tube which connects the boiler to the water chamber several times; keep on doing so until the air bubbles which may have formed have been eliminated (fig.40).*

- During the diagnosis, the following parts are activated sequentially:
- the coffee unit in order to perform a correct start positioning;
- then the cup dispenser in order to perform the loading of the first column of cups in the release device.

During the subsequent initialisation stage:

- the instant drinks boiler, if present, and water chamber fill up;
- 2 complete vends of extremely long coffee are performed automatically for the purpose of filling the boiler of the coffee unit.

- when the hydraulic circuit has been filled, the heating stage begins which automatically activates the heating elements of the boilers.



### Important

*When the boiler is completely filled, carry out several cleansings of the mixer in order to remove possible residues in the hydraulic circuits.*

NB: To enable dispensing tests or cleansings, see the use of the pushbutton panel in "Service" mode (fig.41).



- After having performed these operations, wait about ten minutes until the operating temperature is reached.

### 6.5.3 Cleaning the parts in contact with foodstuffs

With the distributor switched on, perform several cleansing cycles of the mixers pressing the buttons according to the matters described in the service functions so as to eliminate any residual dirt from the coffee boiler and the instant product boiler.

- Wash your hands carefully.
- Prepare a chlorine based anti-bacterial cleaning solution (products that can be purchased in chemists) following the strengths given on the product instruction labels.
- Remove all the product containers from the distributor (fig.42).

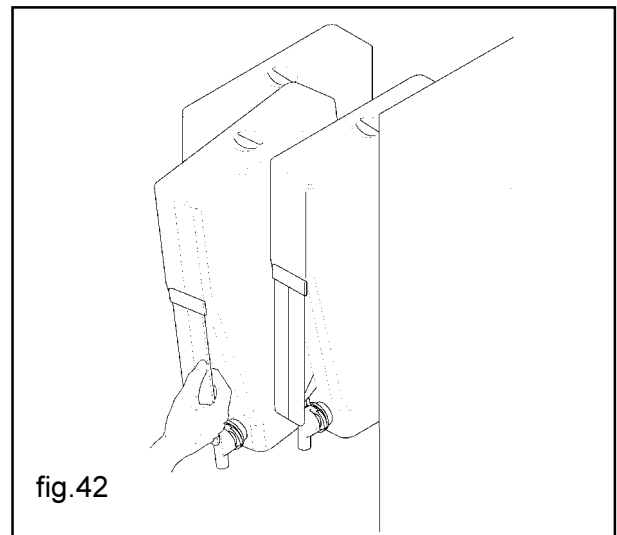

- Remove the lids and product chutes from the containers (fig. 43). Immerse all items into the solution previously prepared.

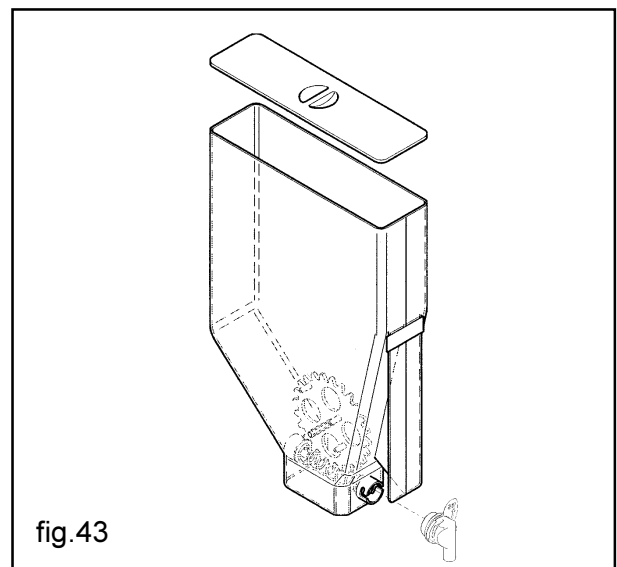

- Remove all the powder chutes, water funnels, mixing chambers and impellers and silicone tubes; also immerse these parts in the prepared solution (fig.44).

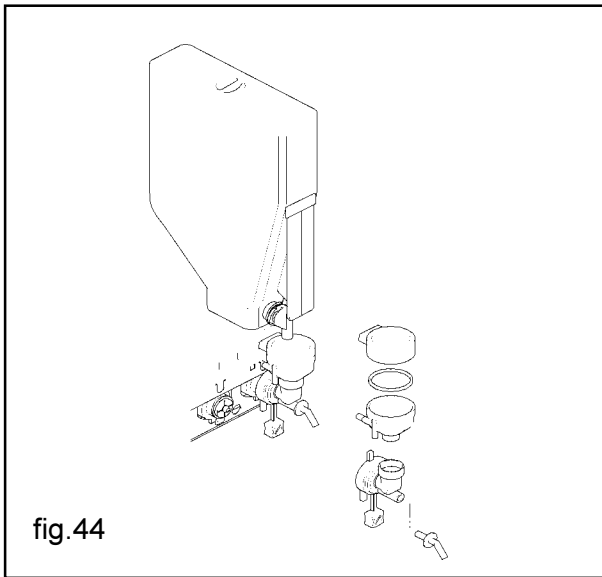

- With a cloth soaked with the solution clean the mixer assembly base (fig.45).

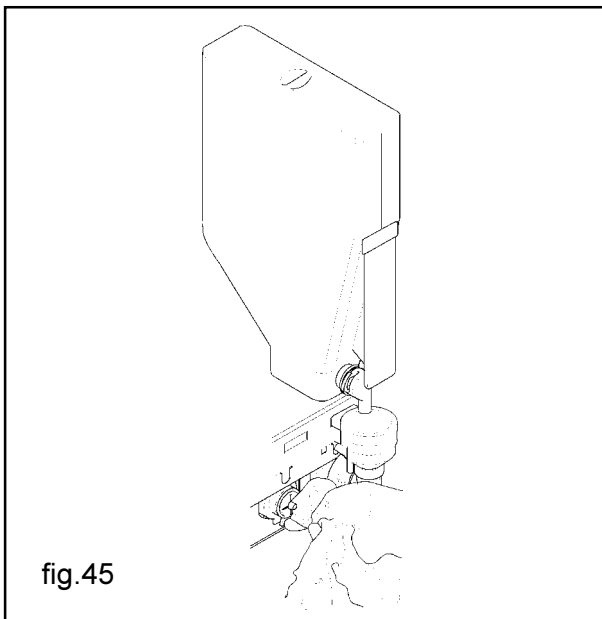

- The parts must be left to soak in the solution for the amount of time indicated on the instruction label.
- Recover all the parts, rinse them thoroughly, dry them perfectly and proceed with their re-assembly in the distributor.

**⚠ Danger**

*For added safety, after reassembling the parts, perform several automatic cleansing cycles so as to eliminate possible residues.*

## 6.6 Product loading

### 6.6.1 Container loading

- the loading of the product containers can be performed without taking them out of their housing; should it be necessary to take them out, take care to close the sliding door that is mounted on the exit chute of products (fig. 46). Particularly, for the coffee bean container, it is necessary to close the hopper sliding door before removing the container.

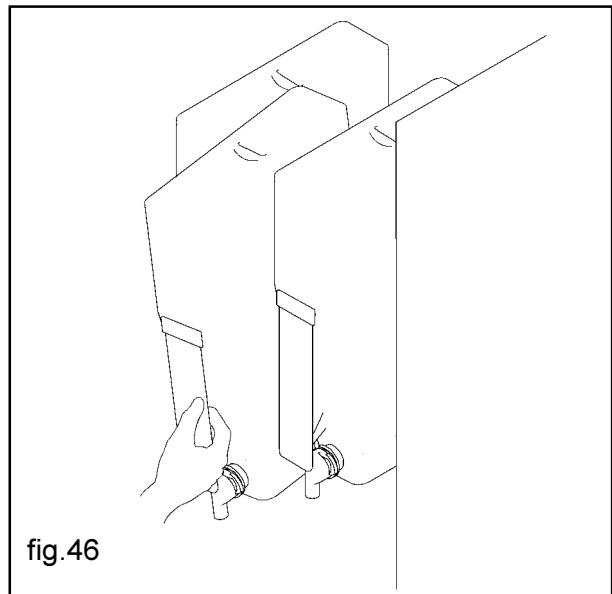

**NB:** You can also load containers without taking them out of the supports.

- Lift the cover of each container and load the product (fig.47)

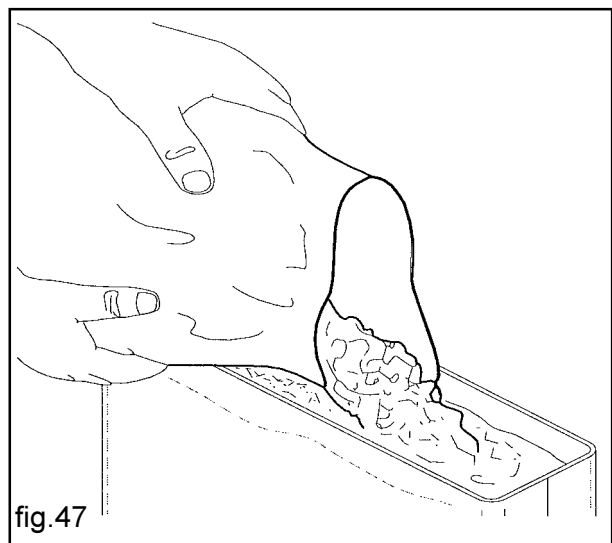

- Make sure there are no lumps; avoid compressing the product or using an excessive quantity, to avoid ageing. We suggest filling the containers with the quantity of product needed for the consumption estimated within two subsequent loadings (fig.48))

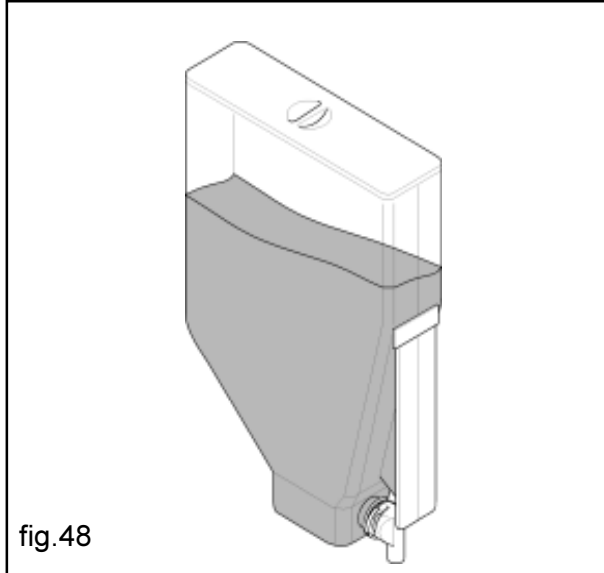

fig.48

Check the capacity of each container in the TECHNICAL SPECIFICATIONS section.

### 6.6.2 Label insertion

- The labels indicating the product selections must be inserted in the special slots according to the order indicated (see fig. 60).

Perform the operation as follows:

- Remove the cup dispenser(fig. 49).

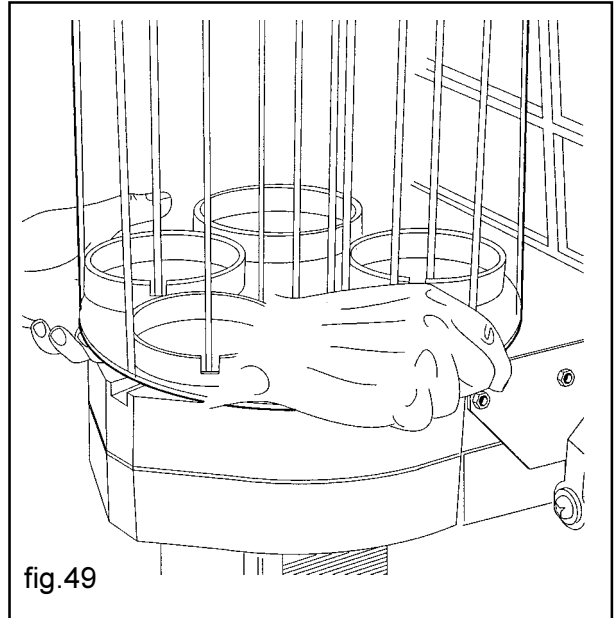

fig.49

- Insert the labels in the order according to the selections used on the vending machine (Fig. 50).
- Re-assemble the cup dispenser.

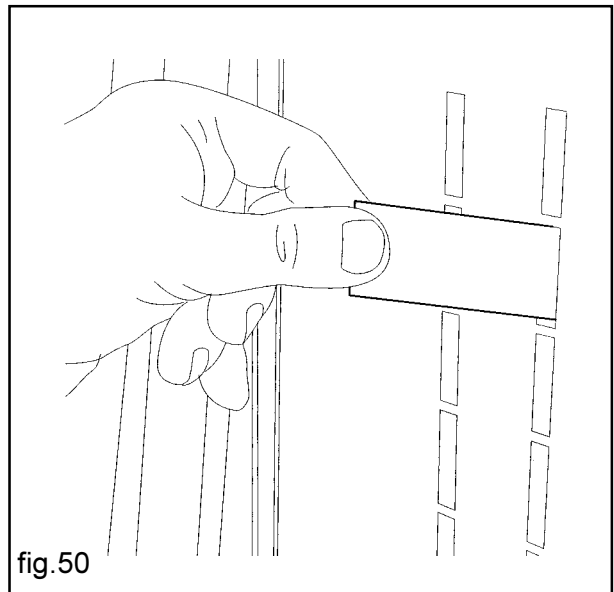

fig.50

### 6.6.3 Cup loading

Use only cups designed for automatic vending machines, with a diameter of 70-71 mm, avoid compressing the cups together during loading.

**ATTENTION: DO NOT TRY TO ROTATE THE CUP DISPENSER MANUALLY.**

In the installation phase with the cup dispenser completely empty, operate as follows:

- Before switching on the vending machine, load a column of cups as long as it is not the one correspondent to the dispensing ring (fig.51).

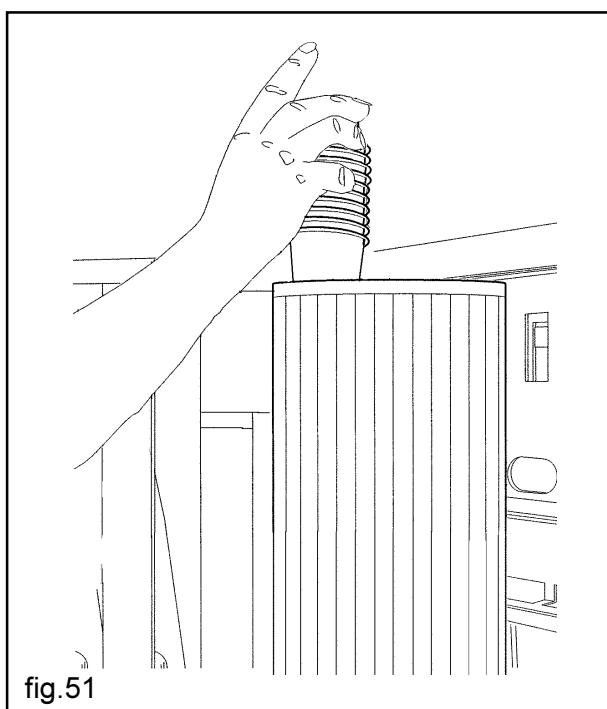

fig.51

- Insert the key in the door switch (fig.36) and wait until the column is positioned in the cup dispensing ring.
- Load all the other columns anticlockwise.
- Replace the lid on the cup dispenser (fig.52).

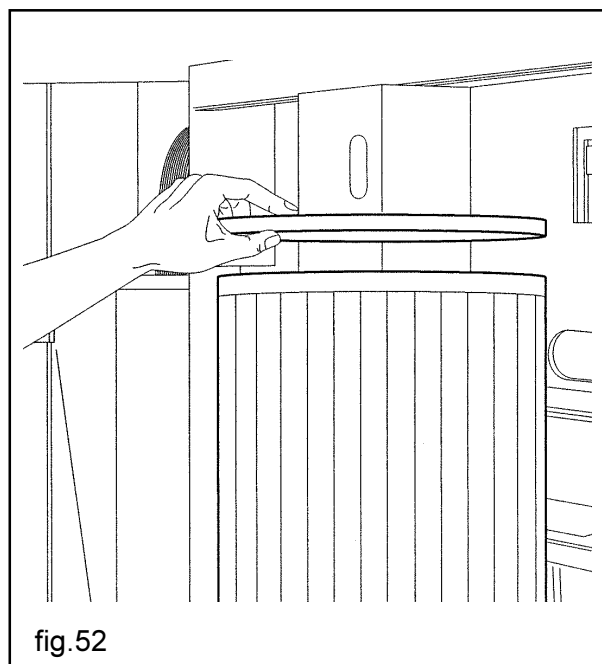

fig.52

### 6.6.4 Spoon loading

- Remove the metal counter-weight from the spoon dispensing box (fig.53).

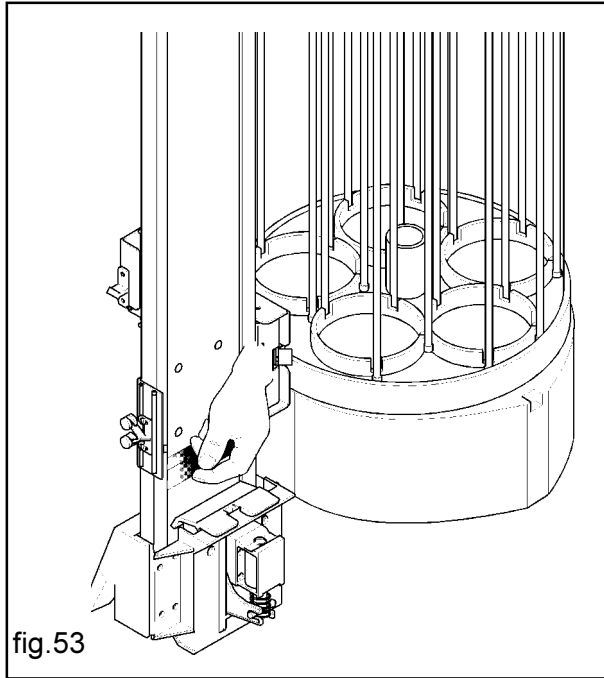

fig.53

- Insert the spoons with their pack wrapping in the column and when they are positioned on the bottom, cut and remove the wrapping (fig.54).

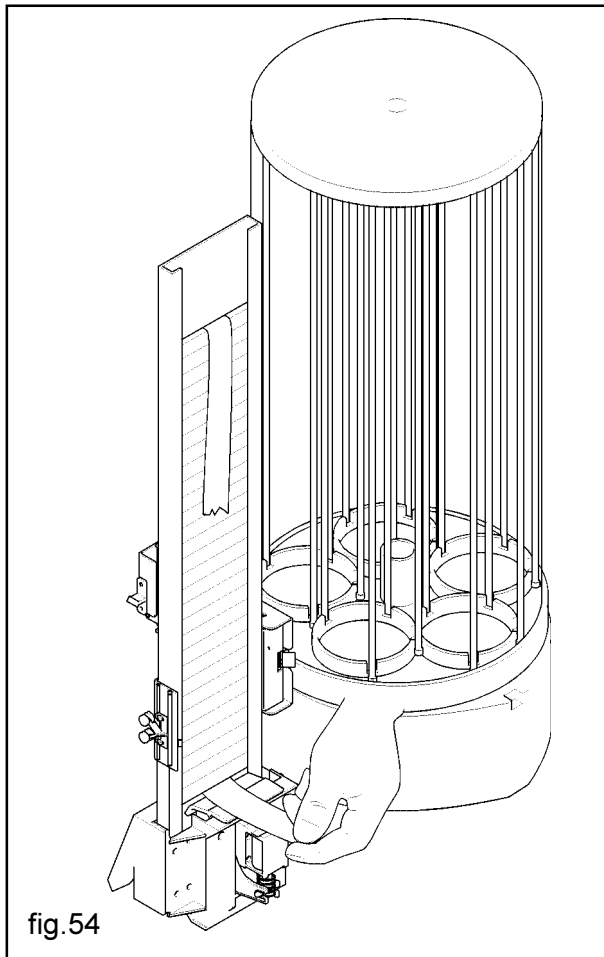

fig.54

- Once the loading is completed, replace the counter-weight. (fig.55).

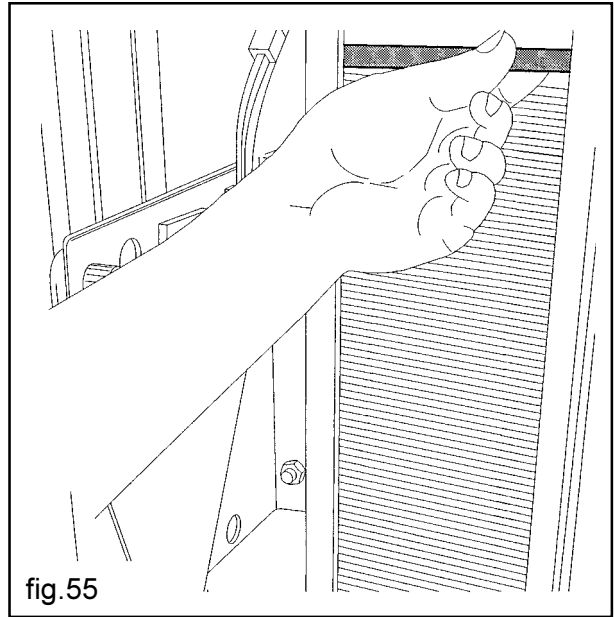

fig.55

- Take care the spoons have no burrs, are not bent and are all placed horizontally.

### 6.6.5 Coffee grounds bag insertion

- Take the coffee dregs chute out of its housing.
- Put the bag locking spring onto the chute.
- Insert the plastic bag, wrapping it around the chute and securing it with the spring (fig.56).
- Re-insert the chute in the guide.

Use short plastic bags so that they do not touch the bottom of the distributor.

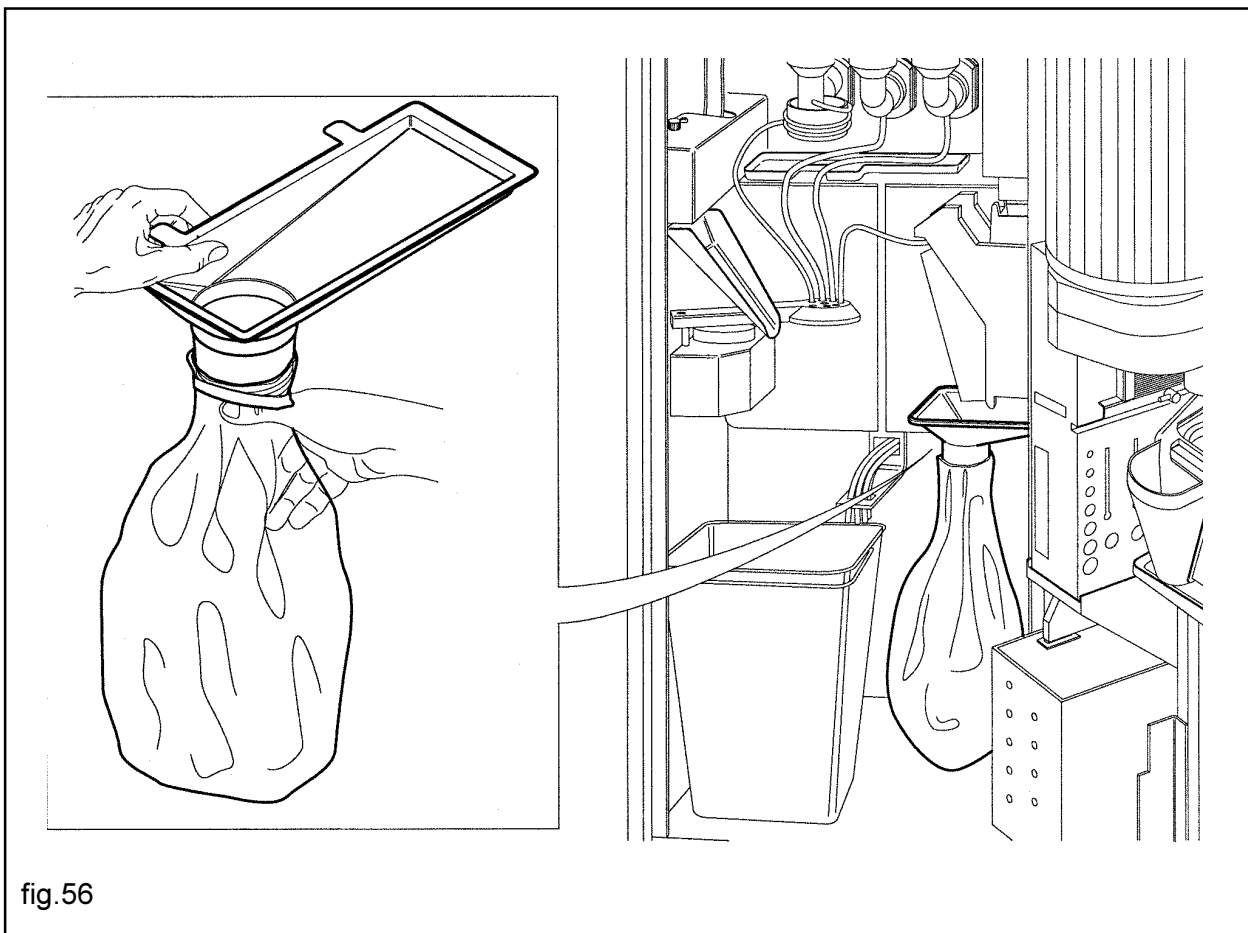
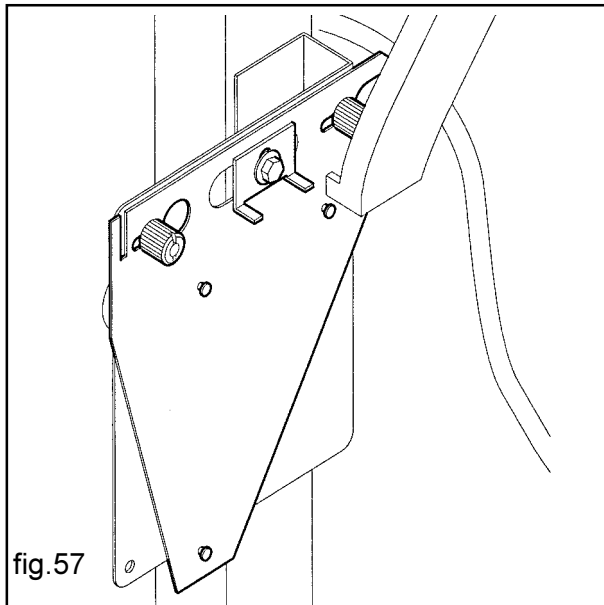

fig.56

### 6.6.6 Payment system installation

The distributor does not have a payment system; any possible damage to the distributor itself and/or persons and/or property deriving from its incorrect installation are the responsibility of the installer of the payment system.

- Remove the support bracket from the machine (fig.57).



- Hook the coin mechanism to the support brackets (fig.58).
- Fix the support with the two knobs.
- Connect the coin mechanism to the C.P.U. board.

NB. The 24V dc coin validators and MDB systems must be directly connected to the CPU board; the Executive serial systems are connected to the CPU via the interface cable supplied with machine.

The 12V dc coin validators require a special interface board in order to be connected to the CPU board.

Then access the programming for the correct settings.

Consult section "7.0 PROGRAMMING" in order to verify if the parameter setting is consistent with the system used.

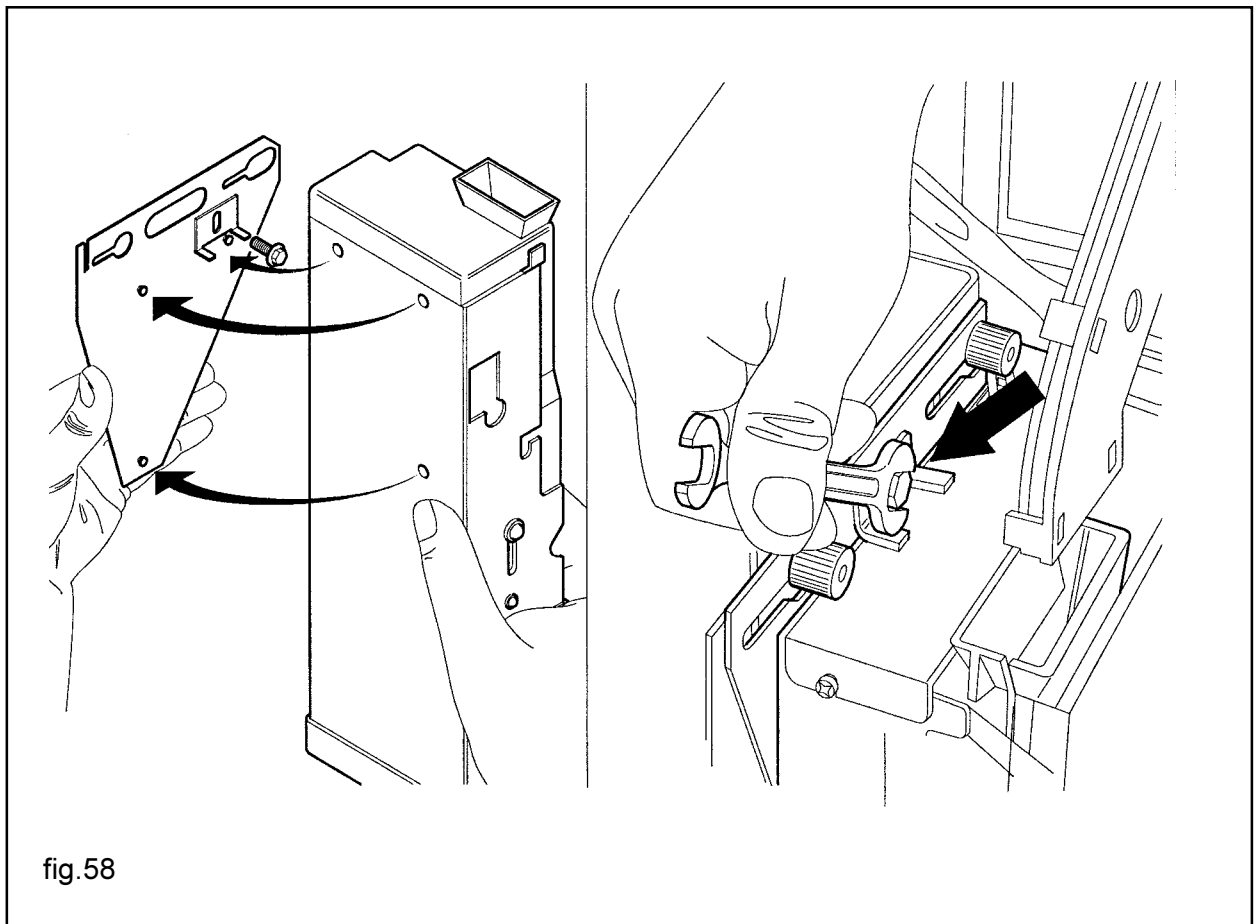

## 7 - PROGRAMMING

With the programming procedures described in this section, it is possible to set all the parameters related to the machine configuration, the setting of the individual doses and drink prices and also obtain sales statistical data.

The “dialogue” between the operator and the machine occurs by means of the 16 digit liquid crystal display and the use of the selection keyboard.

### Programming key

The programming function is accessed by pressing the button 1 positioned on the C.P.U. board (fig.59); the request for the access code to be entered by means of the keypad, will appear on the display.

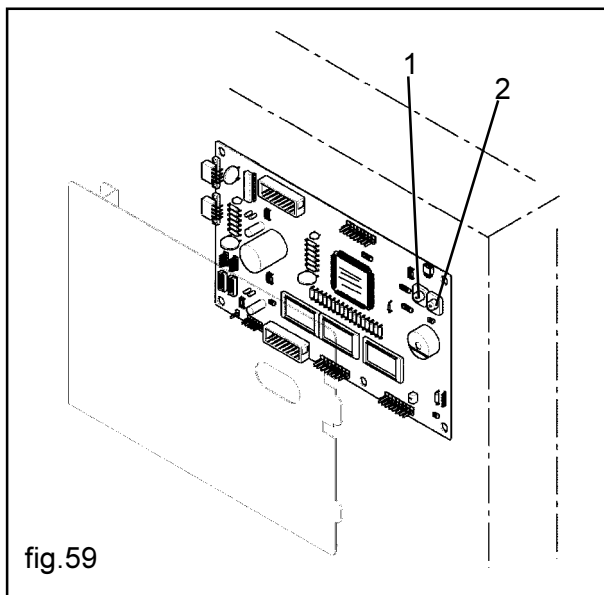

fig.59

- The display messages can be shown in two different languages that can be selected at choice by the operator during the installation phase.

NB: seven languages are available, by using the eeprom language kit.

The programming data can be of two kinds:

### ➤ NUMERICAL DATA

That is all the data that refers to the water, powder, prices, time and date settings.

### ➤ LOGICAL DATA

That is all the data that refers to the logical statuses of the OPTION menu that describes the condition (enabled or disabled) of a specific function.

For programming, some of the keys of the keyboard are used (fig 60), namely:

- Key PRESEL: DECAFF./ “PRG” exits from the current programming sub-menu to go back to the original sub-menu.
- Key 1 or STRONG COFFEE / + has the double function of increasing the value of a selected figure (e.g.: the value of a dose) and/or scrolling forward the list of functions available in the sub menu.
- Key 2 or LONG COFFEE / - is the decrease key and has the function of decreasing the value of a selected figure.
- Key 3 or COFFEE WITH MILK / NUMBER allows the user to move the display cursor in correspondence with the digit that is to be changed by means of the previous keys + and
- Key 4 or CAPPUCCINO / ENTER (also identified as E) used to confirm the changes made or scroll through the option menu.

Once the parameter modifications have been concluded, you can exit from programming mode by pressing key 1 again on the C.P.U. board (fig.59).

KEYBOARD (fig.60).

Maintenance – “Service” Mode

The external keyboard besides being used for the selections is also partially used for programming and maintenance.

In particular the keys and their functions are:

Programming

a= presel. decaffeinated      prg

1= strong coffee

2= long coffee

3= coffee with milk

4 = cappuccino

+ (increase)

- (decrease)

cursor number/

cancel

enter confirm

a= presel. decaf.

b = extra milk

c = without cup

d = sugar stop

1= strong coffee

2= long coffee

3= coffee with milk

4 = cappuccino

6= milky coffee

7= milk

test without cup,

sugar and spoon

water test

test selections

complete

failure reset

coffee unit rotation

chocolate mixer

cleaning

tea mixer cleaning

milk mixer cleaning

dispensing nozzles

movement

electronic counter

reading

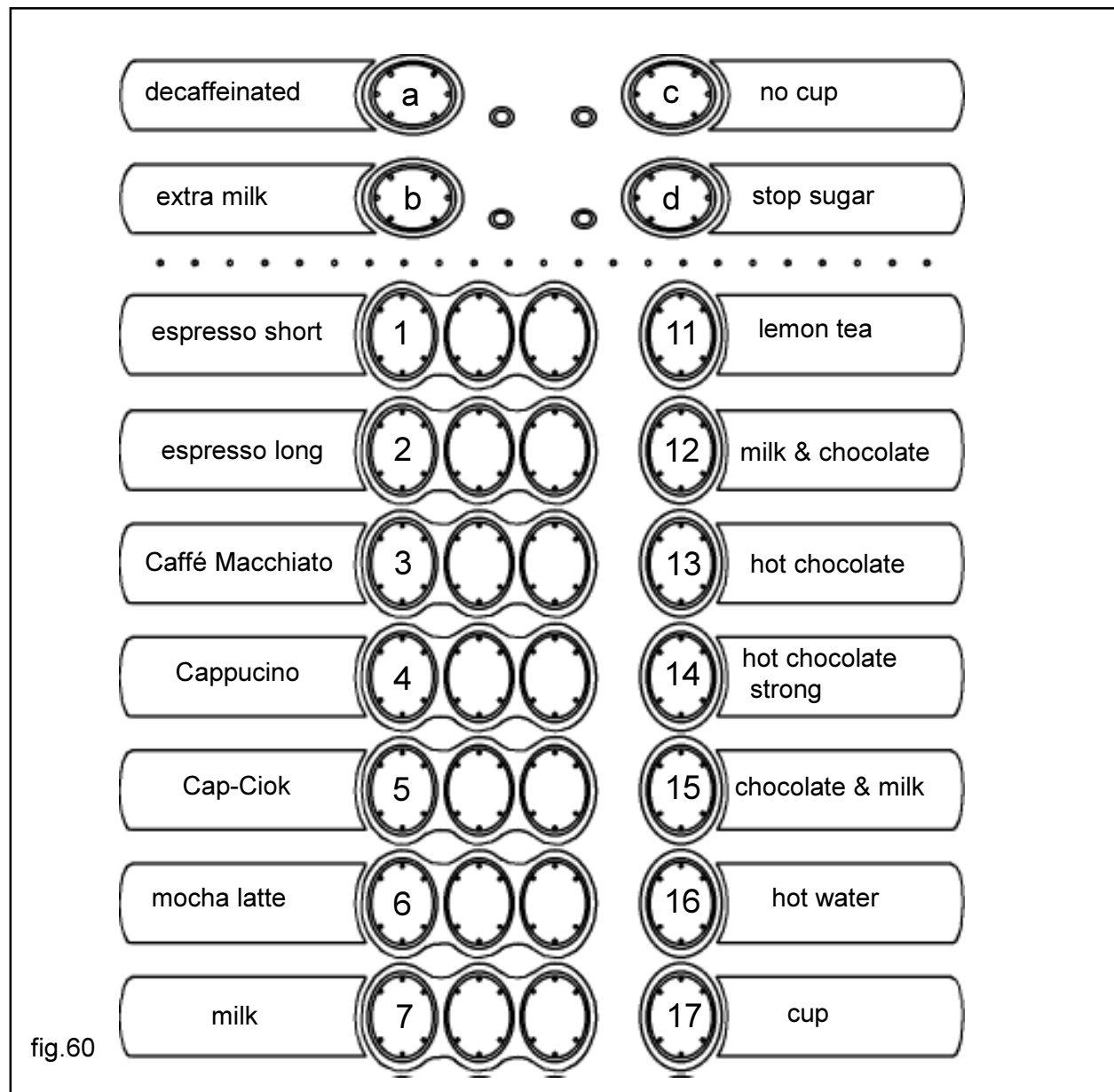

fig.60

Structure of job menus

To access the programming it is necessary to know the access code or password

cod. 00000

The code to be entered is composed of five digits.

The cursor appears under the first digit; using the keys “+” and “-“ (1<sup>st</sup> and 2<sup>nd</sup> on the keyboard) increase or decrease the number; using the 3<sup>rd</sup> key (“number”) move the cursor.

Repeat the operations until the access code is composed.

Once the code is composed, press the key “Enter” (4<sup>th</sup>) so as to access the programming mode.

**Attention**

the default code is 00000

After entering the code, the display visualises the first function:

- by pressing ENTER you access the first function;
- by pressing + the next function will be displayed;
- by pressing PRG you exit from the job sub menu (see example a).

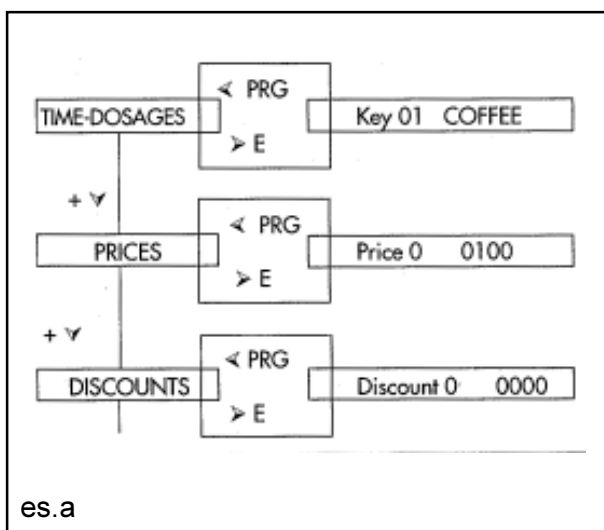

N.B.: If you are in selection mode you can pass to the programming mode.

If you are in SERVICE mode, first, go to SELECTION, pressing key 2 (fig.60) then go to PROGRAMMING, pressing key 1 (fig. 60).

The main menu is composed as follows:

- |                 |             |
|-----------------|-------------|
| TIMES-DOSES     | OPTIONS     |
| PRICES          | COINS       |
| DISCOUNTS       | SALES       |
| PRICE-SELECT.   | TEMPERATURE |
| INCLUDE-SELECT. |             |

To exit from the programming mode press “PRG” until one of the above listed functions appears on the display, then press the programming key positioned on the C.P.U. board (key 1, fig.59) in order to return to the selection mode.

After adjusting the machine and setting prices, coin ducts and configuration, it is possible to store all this data in a portable device called the SAECO ELECTRONIC KEY (fig.61) and use the same configuration for other machines of the same model.

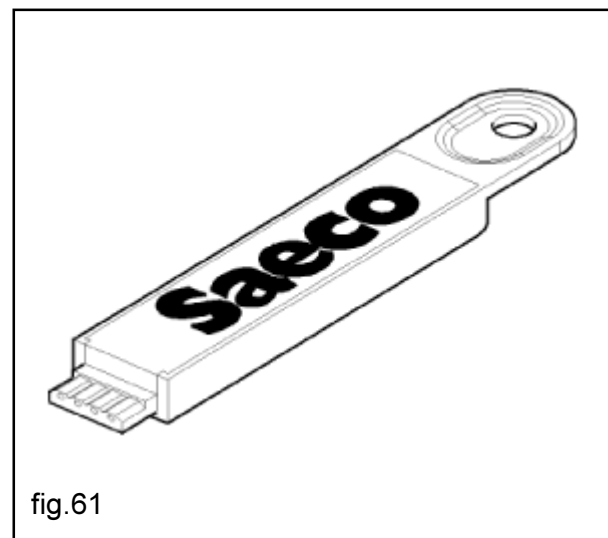

The connection between CPU and the SAECO ELECTRONIC KEY device occurs by means of direct connection to the CPU card; check the position of the connector on the card for the connection (ref. 1, fig. 62).

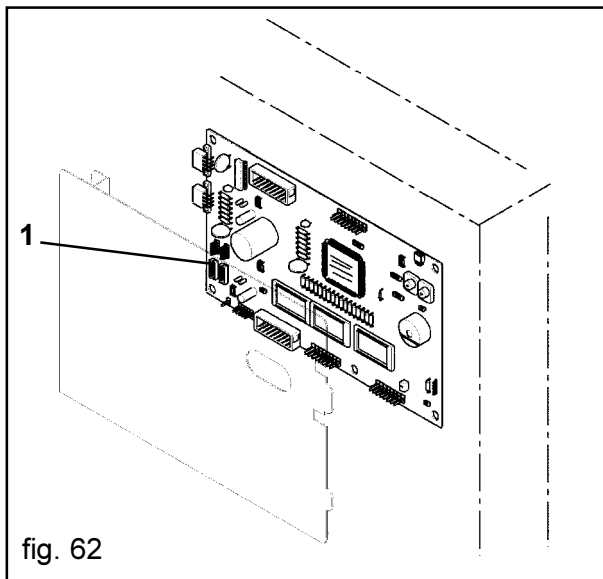

fig. 62

Data will be stored in the SAECO ELECTRONIC KEY until a new configuration reading is performed.

In order to use the SAECO ELECTRONIC KEY proceed as follows:

- Turn off the machine and insert the SAECO ELECTRONIC KEY device into the appropriate connector on the CPU card (ref. 1, fig. 62); then turn on the machine.
- The display screen asks the following question: "CPU > KEY?".
- To read the machine configuration to be transferred to the SAECO ELECTRONIC KEY, press key 4 on the keyboard (with ENTER function).
- For the writing of the machine configuration with the content of the SAECO ELECTRONIC KEY, press key 1 (with INCREASE + function)
- The display screen asks the following question "KEY > CPU?": press key 4 on the keyboard (with ENTER function) to confirm.

**! Caution**

Connect and disconnect the SAECO UPDATE device to and from the CPU card when the machine is switched off.

The following example "b" shows how to move through the menu using the keys "+, ENTER, PRG".

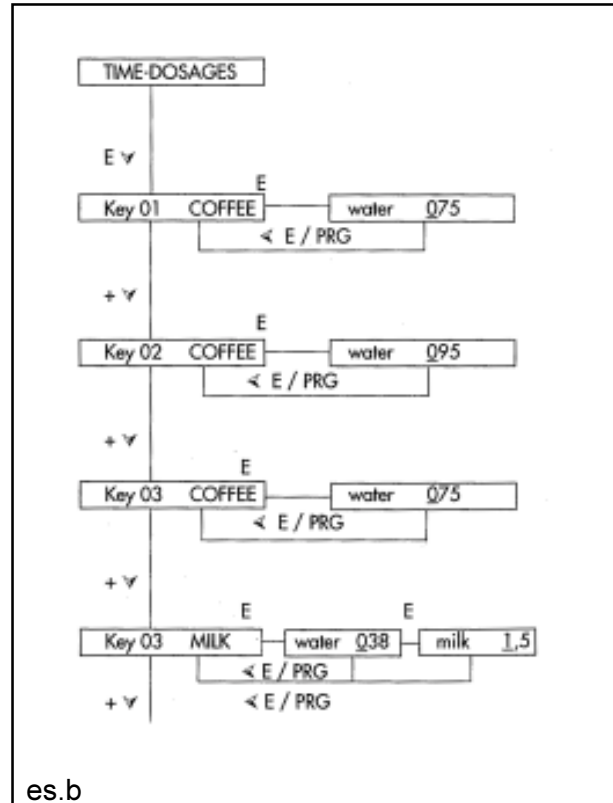

The example below shows how to perform changes in programs:

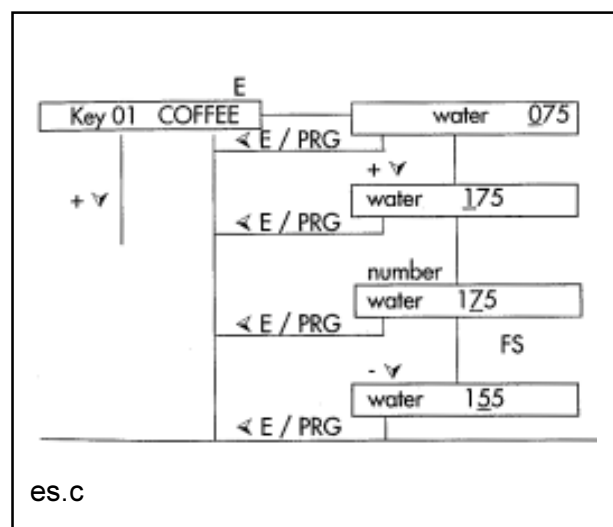

The diagrams illustrated above are valid as examples for all the menus.

## 7.1 Function description

### TIME-DOSES

This menu allows access to the water and product powder dose settings for each available drink.

By pressing ENTER once, this appears on the display:

"Key 01 coffee"

Pressing ENTER again, you can start the dose setting operation for the first selection:

"water 065"

to indicate the water dose.

Using the keys "+", "-", "number", the values of the water dose related to the espresso coffee of selection No. 1 can be changed.

By pressing ENTER again, the dose set is confirmed and the subsequent setting, if any, appears on the display (in case of instant SELECTIONS, the powder) otherwise the program returns automatically to the starting point; this appears on the display:

"Key 01 coffee"

using the key "+" you can scroll through the menu and choose the next selection to be changed.

Below is the combination of the keys and selections indicated in programming:

Key 01 = strong coffee  
 Key 02 = long coffee  
 Key 03 = coffee with milk  
 Key 04 = cappuccino  
 Key 05 = cappuccino with chocolate  
 Key 06 = milky coffee  
 Key 07 = moccaccino  
 Key 08 = milk  
 Key 09 = normal tea  
 Key 10 = normal tea with milk  
 Key 11 = lemon tea  
 Key 12 = milk and cocoa  
 Key 13 = chocolate  
 Key 14 = thick chocolate  
 Key 15 = chocolate and milk

Key 16 = hot water + cup

Key 17 = cup

Key 21 = strong decaffeinated coffee

Key 22 = long decaffeinated coffee

Key 23 = decaffeinated coffee with milk

Key 24 = decaffeinated cappuccino

Key 25 = decaffeinated capp-choc

Key 26 = milky decaffeinated coffee

*Coffee unit time-out:*

maximum activation time of the coffee unit motor (we advise you not to change it)

*Sugar time:*

time for the maximum sugar dose

*Extra sugar time:*

time for the extra sugar dose

*Extra milk time:*

time for the extra milk dose

*Grinder time-out:*

maximum grinding time

The water control of both espresso coffee and instant occurs by means of a volumetric counter. The dosage of instant product powders is expressed in seconds.

### PRICES

Up to 10 prices are available and individually applicable to each selection.

Press Enter to access the price table programming; this appears on the display:

"Price 0 0000"

The vending prices are set using the same procedure used for the dose setting i.e. using the keys "+", "-", "number".

For free vends, all that has to be done is set the vending price to zero.

Press ENTER again to confirm the set value and the next price is visualised on the display:

"Price 01 0000"

Pressing PRG you return to the PRICES menu:

### DISCOUNTS

Up to a maximum of 10 discounts can be programmed (from Discount 0 to Discount 9) for as many vending prices as there are. Furthermore it is possible to program a special discount for the exclusion of the cup (indicated with SB).



#### **Attention**

*The discounts S0-S9 are tied to time bands and consequently to the presence of the clock device on the C.P.U. board.*

*The discount for the cup is available without the clock.*

Pressing ENTER once, the following appears on the display:

"Discount 0 0000"

by using the keys "+", "-", "number", you can carry out the discount setting.

Press ENTER again to confirm the set value and the next discount is visualised on the display:

"Discount 1 0000"

By pressing "PRG" you return to the DISCOUNTS menu.

### PRICE SELECTIONS

This menu allows the combination of each single selection (indicated as Key 1 - Key 26) with the prices previously set (indicated with Price 0 ÷ Price 9).

Press ENTER to go to the sub-menu whose first function allows the operator to program all selections at P0 price; the following appears on the display:

"All at price 0 ? Y/N"

Using the key "+" the desired option is chosen:

Y (=yes) or N (=no)

Selecting the option Yes and pressing ENTER you can pass on to the programming of:

"Extra milk price = 0000"  
 "Extra sugar price = 0000"

these concern eventual price increases for extra milk and extra sugar pre-selections.

Vice versa, selecting the option NO you access the programming of the single price for each single selection as follows:

"Key 1 = Price 0"

using the key "+" or "-" you can scroll through the table of prices, from 0 to 9; once the desired price is chosen, it must be confirmed by means of ENTER, thus proceeding directly to the programming of the next drink.

Of course it is possible to combine more than one selection with the same price.

As before, press the PRG key to exit from the sub-menu.

## INCLUDE-SELECTIONS

This function allows the operator to exclude the unwanted selections (from Key 01 to Key 26), making them unavailable.

By pressing ENTER once, this appears on the display:

"INCLUDE key 01 = Y"

using the keys "+" and "-", the desired option is selected: ENTERING "N" THE SELECTION IS EXCLUDED.

Press ENTER again to confirm the value and go ahead to the next selection.

## OPTIONS

This function makes a series of options available in sequence as listed below; press ENTER to access the sub menu that visualises the first option.

For each OPTION it is necessary to set the logical status "Y" or "N" that does or does not enable the function.

By using the keys "+" and "-", you change logic values, i.e. the status, from "yes" (Y= enabled) to "no" (N= disabled); using the keys "+", "-", "number", you change numeric values.

Pressing ENTER again, you confirm the pre-set value and the next option is visualised on the display; pressing PRG again, you return to the "OPTIONS" menu.

Decaffeinated<sup>1</sup> = enables the freeze-dried coffee pre-selection key

<sup>1</sup> By setting "S" to this option, the lemon tea selection is cancelled (both the lemon tea or decaffeinated option is not possible)

Normal Tea = enables the normal freeze-dried tea selections: "normal tea" and "normal tea with milk" corresponding to the keys 11 and 12

Cup function = enables the cup exclusion pre-selection key

Fresh ground = option for fresh-ground coffee

Spoon always = enables (Y) the spoon dispensing for all types of selections (bitter and/or instant)

Extra milk = enables the extra milk pre-selection key

Motor delay = option to introduce a delay on the instant powder motors

Milk first = option to dispense milk for coffee with milk: first (Y) or after (N) the coffee

Validator = enables (Y) the connection to the coin box-selector

Permanent credit<sup>2</sup> = option to visualise the credit until it runs out (Y) (set the Multivend option to Y)

<sup>2</sup> (The two functions are related; entering "N" for the Multivend option, any Permanent Credit operation will automatically be void)

Executive = enables (Y) the executive coin box (set Y also for the validator option)

Change giver = option to give the change (with the system COGES and RUBBINI – SAECO CARD, set Y)

ECS differentiated = to be enabled (Y) when the COGES ECS system with differentiated prices for keys-coins is used. Leave "N" with non-ECS systems. It is not necessary to set the codes 241, 242, 243 etc. on the machine

PRICE HOLDING = enables (Y) for systems with Price HOLDING protocol

BVD system = enables (Y) BDV coin boxes (available with kit)

MDB- ICP system = enables (Y) MDB coin boxes

Master Slave = enables (Y) for Master/Slave protocol, this option enables the functioning of two machines with a single EXECUTIVE payment system

Multi-vend<sup>e</sup> = option to visualise the remaining credit for 3 minutes (Y) or re-set it (N) at the end of the drink dispensing

Clock = enables the clock (by kit)

Language = language used for displaying all messages (possibility of choosing between two stored languages)

Decimal point = display of the amount with the decimal point

TO pump = enables a maximum operating time of 40 seconds (S) or 120 seconds (N) of the espresso pump

Cleansing = enables the automatic cleansing (available with the clock device)

Cleansing cycle = enables, without expansion boards, a cleansing of the mixers 30 minutes after the machine has been switched on. A second cleansing cycle will follow if no drinks are dispensed within the following 6 hours; at this point the cleaning time restarts from the last drink dispensed. Consequently, one mixer cleaning per day is guaranteed.

Freeze dried product pre-heating = enables the pre-heating function of the hydraulic circuit for selections with freeze dried coffee. Each time a drink is requested with freeze dried coffee, the machine carries out a hot wash with 30cc of water.. This wash is not carried out if, during the previous 3 minutes, a freeze dried selection has been made.

Milk pre-heating = enables the pre-heating function of the hydraulic circuit for selections with coffee with milk. Each time a drink is requested with coffee with milk, the machine carries out a hot wash with 30cc of water.. This wash is not carried out if, during the previous 3 minutes, a selection with milk has been made.

Cleaner \* = step-down counter, with indication for the water softener resin regeneration

Grinder \* = step-down counter, with indication for the replacement of the grinder

Filters \* = step-down counter, with indication for the coffee filter regeneration

\* (In any event, does not stop the distributor operation)

Code = new programming access code

## COINS

This menu is accessed for programming coins (from coin 1 to coin 8) in order to make them compatible with the system used; therefore verify that the coin box channels correspond to the machine channels.

Press ENTER once, this appears on the display:

"Coin 1 0050"

by using the keys "+", "-", and "number" you can change the values.

By pressing ENTER, you confirm the change set or in any event the value visualised on the display and then pass on to the next coin. In particular:

"Coin 7 0000"

This channel is used for setting the value for the obliterator cut or the token, using the specific interface kit.

Press PRG to return to the COINS menu.

## SALES

This function enables access to all selling statistics audited by the machine.

Confirming by means of ENTER, you sequentially enter the following menu of statistics and related management thereof.

By pressing the key "+" you can scroll through the menu described until reaching the required function; pressing ENTER, you access the first item of the selected function and by continuing to press ENTER you can read the other items, if any.

### TOTAL CASH

Total cashed for sales prices, which cannot be reset

### CASH

Total for sales prices

### DISCOUNT

Discounted value total

### OVERPAY

Total cashed without sales

### TOTAL COUNT

Total selection count (sales + tests) which cannot be reset

### COUNT

Total selection count (sales + tests) and total count for each selection.

### FREE

Total count and count for each single selection of "free selections" (free vend key)

### TEST

Total count and count for each single selection of the "test selections"

### COINS

Total for each single coin introduced

### BANKNOTES

Total for each single banknote introduced (only with MDB)

### ERASE ALL

Function for re-setting all the statistics

Pressing the PRG key you return to the original menu.

To reset the data act as follows:

- go to CANCEL
- press ENTER
- COD 0000 will appear on the display
- Enter the resetting code, following the standard procedure
- Press ENTER
- You will be requested if you want to change the resetting code
- Press "+" if you do not want to change the code
- "RESET ?" will appear on the display
- Confirm by means of the NUMBER key

At the end of the resetting, press PRG to return to the original menu.

The data resetting code (4 digits) is different from the programming access code (5 digits).

The default code is 0001



### **Attention**

*If you want to change the default code proceed as follows:*

- When requested if you want to change the code, press ENTER;
- The old code will be displayed;
- Use the keys "+", "-", "number" to compose the new code;
- Confirm using ENTER on completion.

### TEMPERATURE

This menu permits the regulation of the operating temperature of the coffee boiler and the instant drinks boiler in models with double boilers.

By pressing ENTER, the following appears for example:

"Temp. H<sub>2</sub>O Coff. 087"

by pressing ENTER once again, the following appears:

"Temp. H<sub>2</sub>O Inst. 084"

by using the keys "+", "-", "number" you can increase or decrease the temperature of the water in the respective boilers.

In any event the machine is provided with safety limits so that the maximum temperature values set do not exceed these limits.

### DATA FOR MDB

This menu appears when the MDB-ICP(YES) option is included and enables the relevant payment configuration

By pressing ENTER the following is displayed:

"maximum change"

"coin change"

"coins allowed: from 1 to 16"

"banknotes allowed: from 1 to 16"

### MDB TUBES LOADING

This menu appears when the MDB-ICP(YES) option is included and enables the filling of the "change return" tubes of the coin box.

By pressing ENTER the following is displayed:

"Key 3 to end"

Now it is possible to insert the coins in order to load the "change return" tubes; once the operation has been completed, press key 3 to exit.

### MDB TUBES UNLOADING

This menu appears when the MDB-ICP(YES) option is included and enables the emptying of the "change return" tubes of the coin box.

By pressing ENTER this is displayed:

"T3 for coins from 1 to 16"

## 8 - SERVICE

The service (maintenance) functions are accessed by pressing the service button (key 2) on the CPU board as indicated in figure 59.

"SERVICE" appears on the display  
In the service mode the keys of the external keypad identify the functions illustrated in drawing 61, i.e.:

- TEST WITHOUT SUGAR: after pressing the key it is possible to use the keypad as in normal service so as to dispense any selection without cup, sugar and spoon.
- WATER TEST: after pressing the key it is possible to use the keypad as in normal service, so as to dispense any selection with water only.
- TEST: after pressing the key it is possible to use the keypad as in normal service so as to dispense any complete selection (counted as test dispensing).



### **Attention**

*To cancel a test pre-selection without dispensing drinks you have only to press the service key once again.  
In this case the distributor will remain in SERVICE mode.*

- FAILURE RESET: this resets the failures registered by the distributor and launches a subsequent diagnostic control in order to check that there are no other failures.
- COFFEE UNIT CLEANING: this performs a cycle of the coffee unit (ESPRESSO version).



### Attention

In the presence of faults, this key has the function of scrolling through the list of the anomalies memorised by the distributor.

- MIXER-1 WASH: this allows the cleansing of the milk mixer
- MIXER-2 WASH: this allows the cleansing of the tea mixer
- MIXER-3 WASH: this allows the cleansing of the chocolate mixer
- MIXER-4 WASH: it allows the cleansing of the tea mixer
- TOTAL VENDS: makes it possible to display the number of drinks dispensed (general meter). To return to the service mode you have to press the service key again.
- NOZZLE MOVEMENT: allows the movement of the nozzles.

## 9 - MAINTENANCE AND INACTIVITY

### 9.1 Cleaning and Loading

#### Attention

In order to guarantee the correct functioning of the distributor over time, it is necessary to carry out certain operations regularly, some of which are indispensable for the purpose of complying with current health regulations. These operations must be carried out with the distributor open and off; cleaning must occur before loading products.

#### 9.1.1 Daily cleaning

The objective is to prevent formation of bacteria in the areas which come into contact with food. The tools necessary for performing cleaning operations are: small brushes, clean cloths and drinkable water.

Operate as follows:

- Wet the cloth and clean all the visible parts in the dispensing area (fig.63 and fig.64).

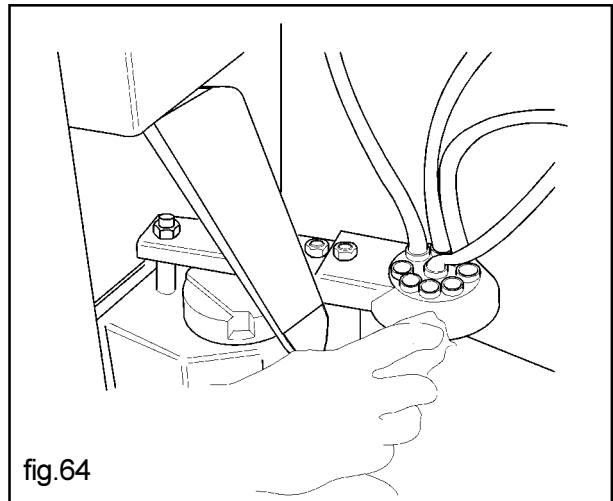
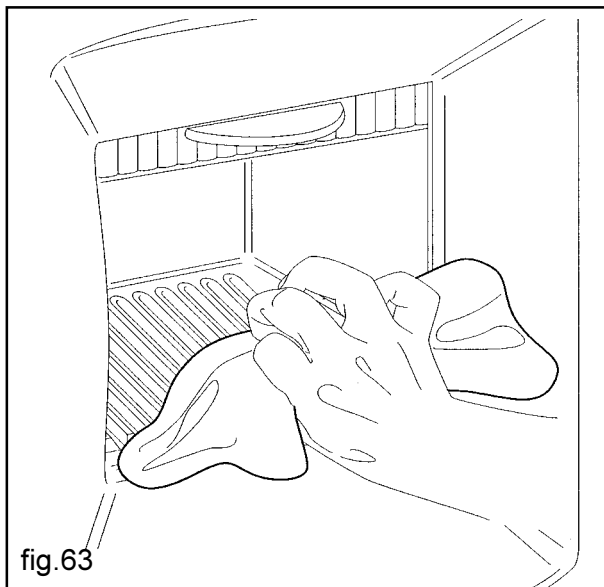

Remove and clean carefully the following:

- powder conveyors (ref.1, Fig.65), suction chamber (2), ring (3), water conveyor (4), mixing bowl (5), mixer fan (6)
- silicone dispensing tubes (fig.64)

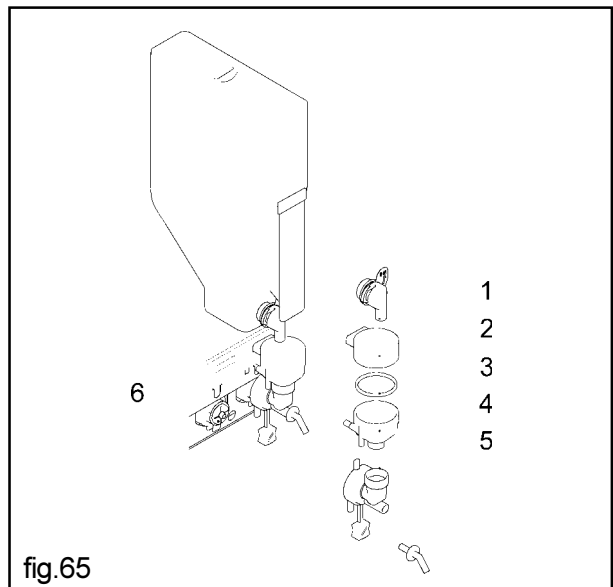

- dispensing chamber (fig.66)

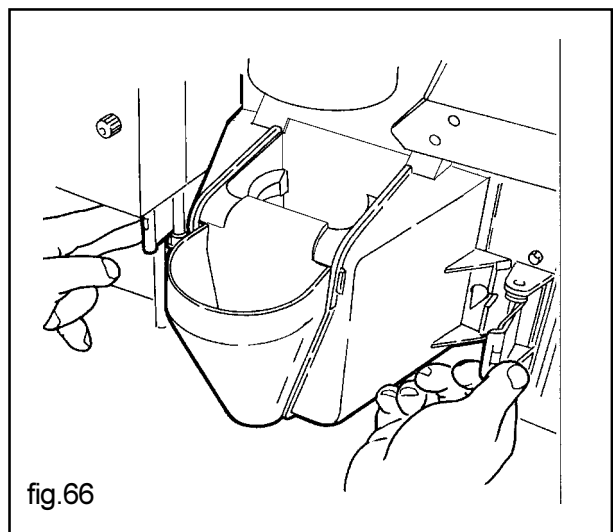

- chute and coffee funnel (fig.67)

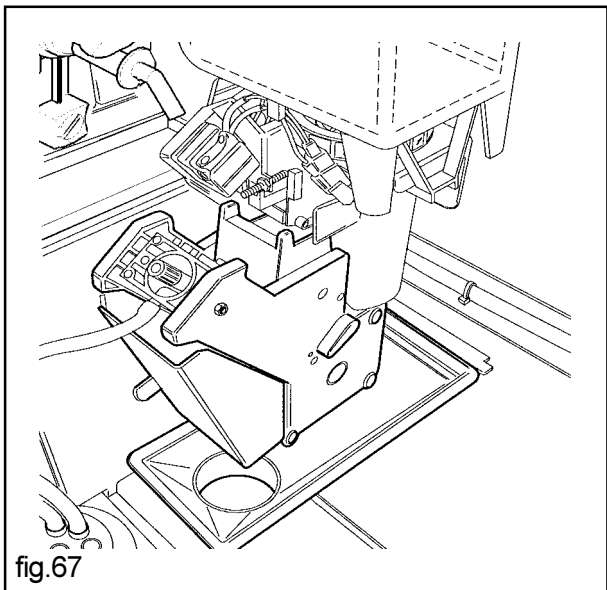

Before re-assembling, dry all the elements carefully.

- pull out the unit to facilitate cleaning (fig.68) and with the small brush, clean any residual coffee powder off the unit.

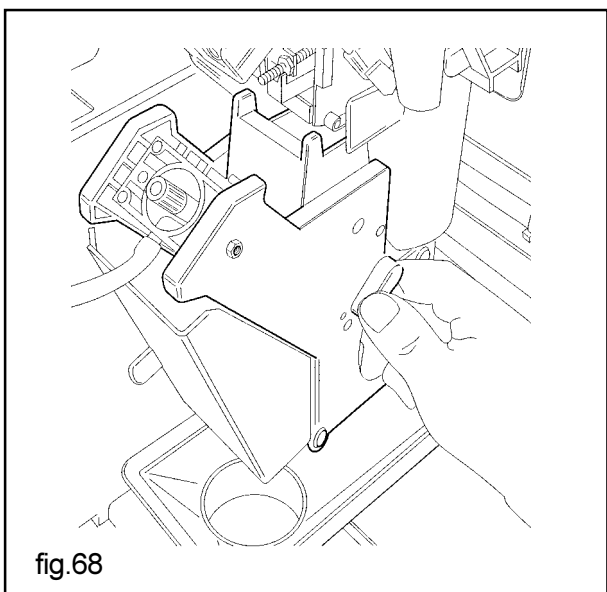

- empty the liquid waste bin, clean it and/or replace it (fig.69)

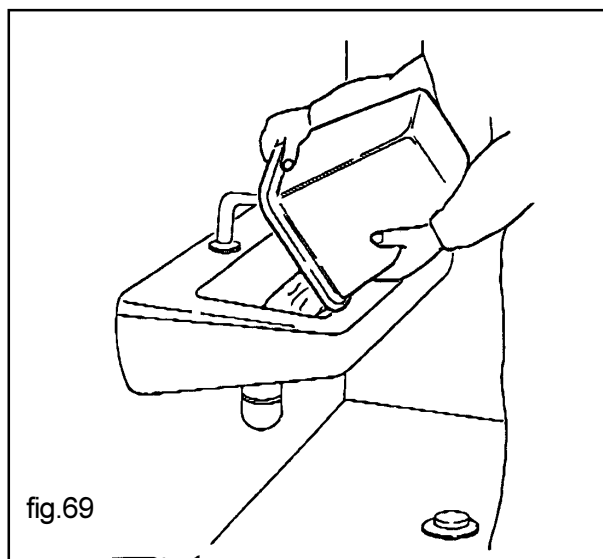

- Replace the coffee grounds bag (coffee in grains versions) (fig.70).

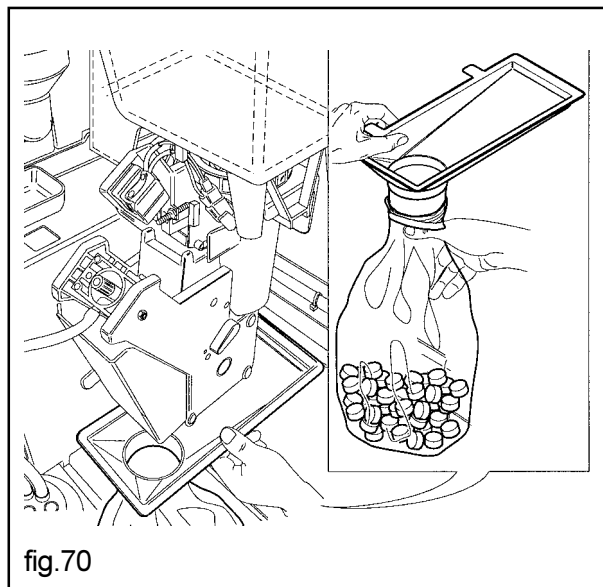

### 9.1.2 Weekly cleaning

Remove all the containers and clean with a wet cloth all the container support parts, as well as the bottom and the outside of the distributor, in particular the dispensing area (fig.71)

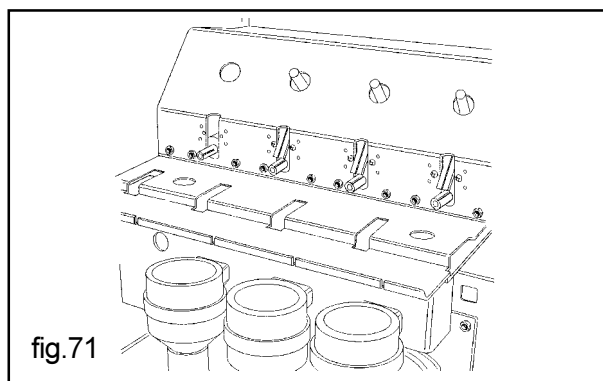

### 9.1.3 Product loading

When necessary, take steps to load the products and/or consumable materials of the automatic vending machine.

For these operations please refer to the initial installation operations described in Section 4.

## 9.2 Maintenance

	EVERY DAY	EACH WEEK	EACH MONTH	EVERY SIX MONTHS	EVERY 10.000 DRINKS
Remove and clean all the visible parts in the dispensing zone	■				
Empty the liquid waste-bins, clean and/or substitute them	■				
Replace the coffee grounds bag	■				
Remove all the containers and clean with a wet cloth all the container support parts, as well as the bottom and the outside of the distributor, in particular the dispensing area		■			
Disinfect all the parts in contact with food			■		
Remove and rinse the coffee unit, lubricate all the moving parts using silicone grease for alimentary use			■		
Replace gaskets and filters					■

### 9.2.1 Ordinary and extraordinary maintenance

The operations described in this section are purely indicative as they are tied to variable factors such as the water hardness, humidity, products used and workload, etc.

#### **Caution**

*For all operations requiring the disassembly of distributor components make sure the machine is off.*

Entrust the operations mentioned below to qualified personnel. Should it be necessary to leave the distributor switched on, use specially trained personnel.

For more complicated measures, such as boiler descaling, satisfactory knowledge of the equipment is necessary.

Disinfect all parts in contact with foodstuffs on a monthly basis using chlorine-based solutions, following the procedures already described in Chapter 4.

### 9.2.2 Coffee unit maintenance

Plastic unit. It is advisable to remove the unit and wash it thoroughly in hot water on a monthly basis; every 5,000 vends and in any event on a monthly basis, it is advisable to lubricate all the moving parts of the unit, using silicone grease for alimentary use (fig.72):

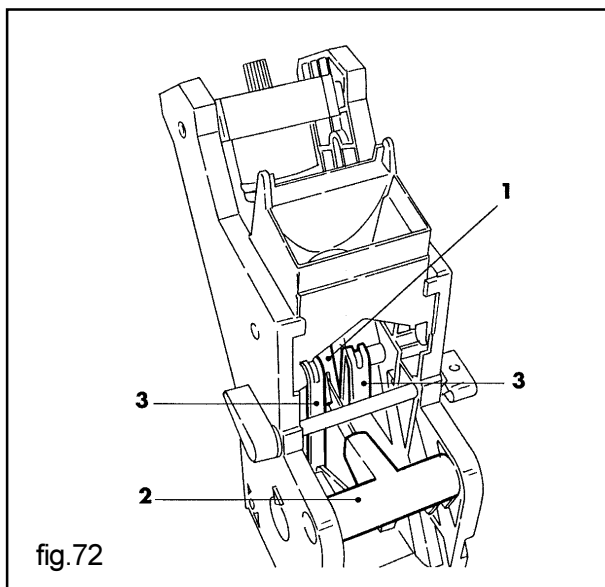

- lower filter rod (1)
- connecting bar (2)
- guide rods (3)

Every 10,000 vends we advise you to substitute gaskets and filters.

- gaskets

For the upper filter (fig.73):

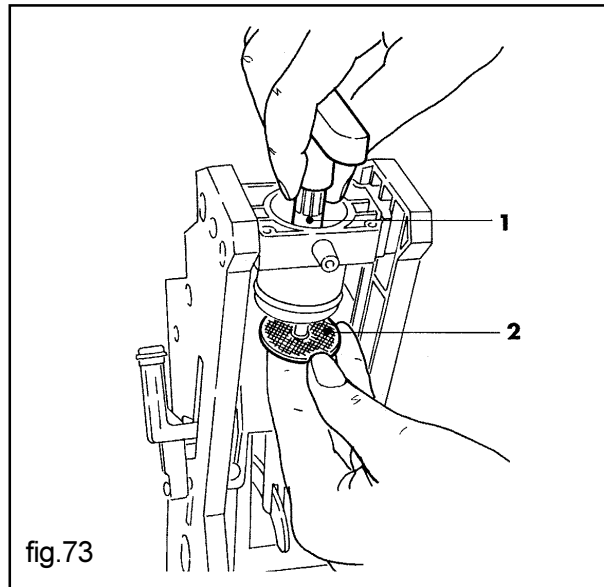

- Loosen the upper pin (1) using the spanner provided
- Unscrew the filter manually (2)

For the lower filter:

- Unscrew the two side screws (ref.1, fig.74) and remove the upper piston block (2)

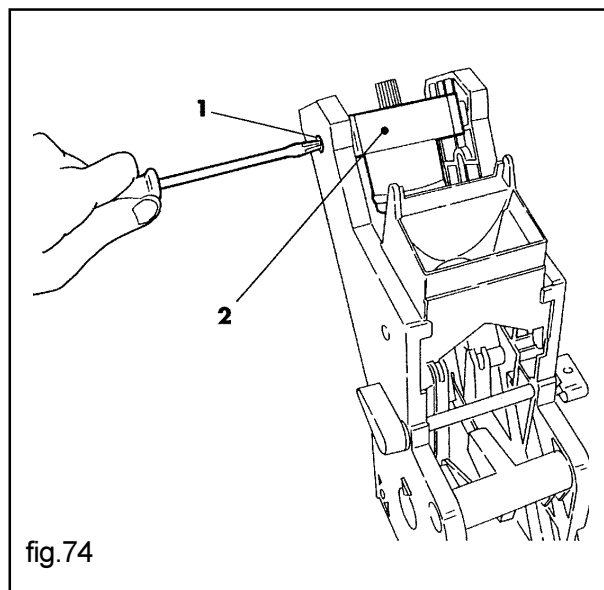

- Using the spanner provided, manually rotate lower filter until it is flush with the cup (fig.75)
- Unscrew the screw (1) and replace the filter (2)
- Re-assemble everything in inverse order

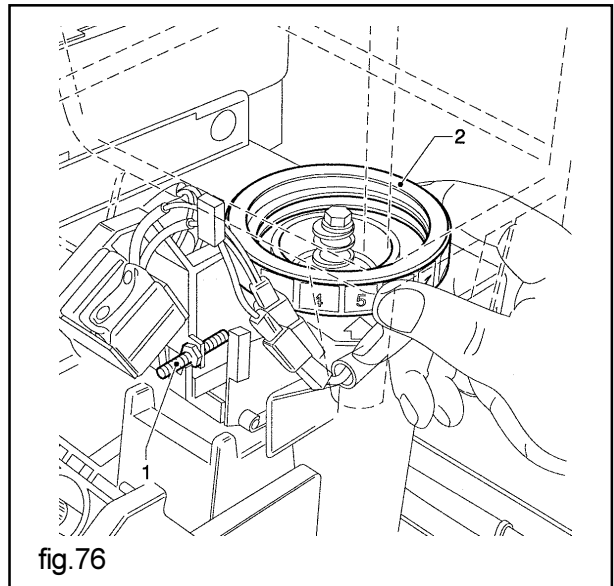
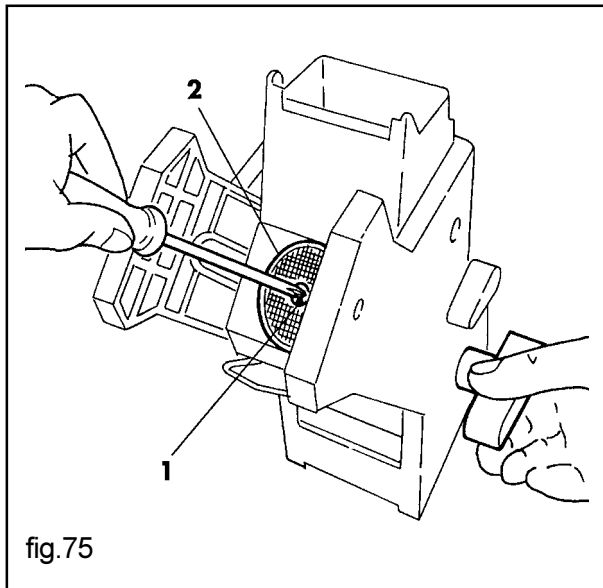

- Each complete turn corresponds to a variation of 0.15g.
- Regulation of the degree of grinding. Turn the ring nut (ref.2, fig.76) so as to obtain the desired results.

## 9.3 Settings

### 9.3.1 Dosage and grinding regulation

The distributor comes already adjusted to standard settings, i.e.:

- Temperature of the coffee in the cup of about 78°C for 38 cc of dispensed product
- Temperature of instant products in the cup of about 73°C
- grams of coffee powder, about 7.2 grams
- grams of instant powder products according to the matters indicated in specific tables

In order to obtain the best results with the product used, we advise you to check:

- Grams of ground coffee. Vary the quantity by turning the screw on the doser (ref.1, fig.76)

After each regulation, three selections are necessary before obtaining the new granulometry.

## 9.4 Resin regeneration (where the water softener is provided)

The regeneration of resins must be performed in relation to the water in the mains network to which the distributor is connected.

The table indicated below can be used as a reference:

WATER HARDNESS	NUMBER OF SELECTIONS	
	°French	60cc
10	25000	12500
20	12500	6000
30	9500	4500
40	6500	3000
50	5000	2500

In order to ascertain the degree of water hardness and consequently the time and type of intervention, specific kits available on the market can be used.

The operation can be performed on the distributor as follows:

- switch off the machine
- turn the lower tap taking care to place the related hose in a bucket or better still in a drain (fig. 77)

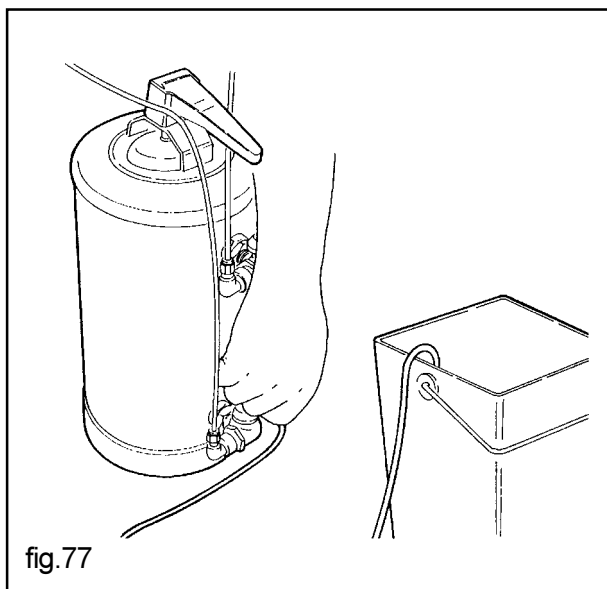

- remove the cover and introduce 1.5 kg of normal cooking salt (fig.78)

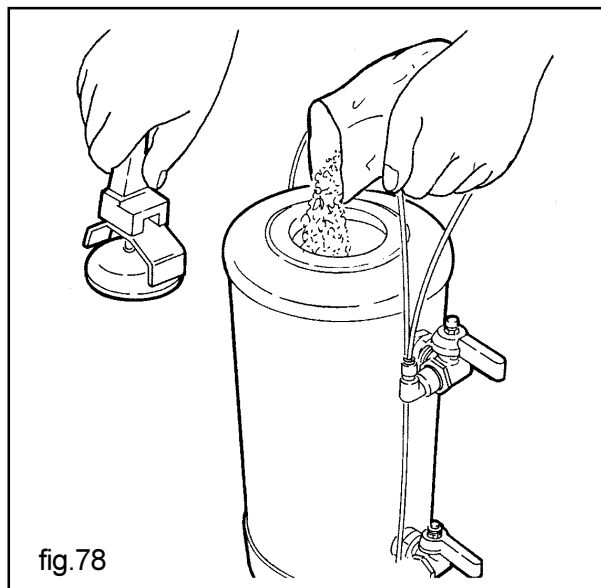

- replace the cover
- switch on the machine and let the water pour out until it is no longer salty
- switch off the machine and close the tap (fig.79)

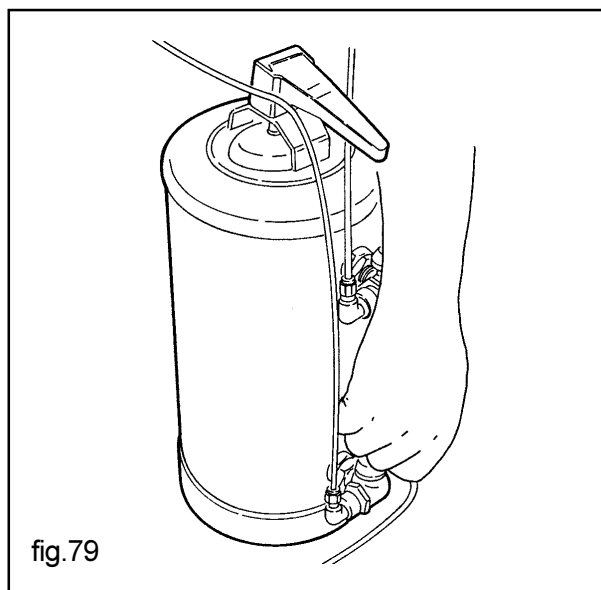

This operation takes about 30/45 minutes.

## 9.5 Inactivity

If the automatic vending machine remains inactive for a long time it is necessary to take certain preventive measures:

- disconnect the machine electrically and hydraulically;
- completely empty the instant drinks boiler and the chamber incorporating the float, removing the plug located on the hose along the drain chute;
- replace the plug once the draining has been completed (fig.80);

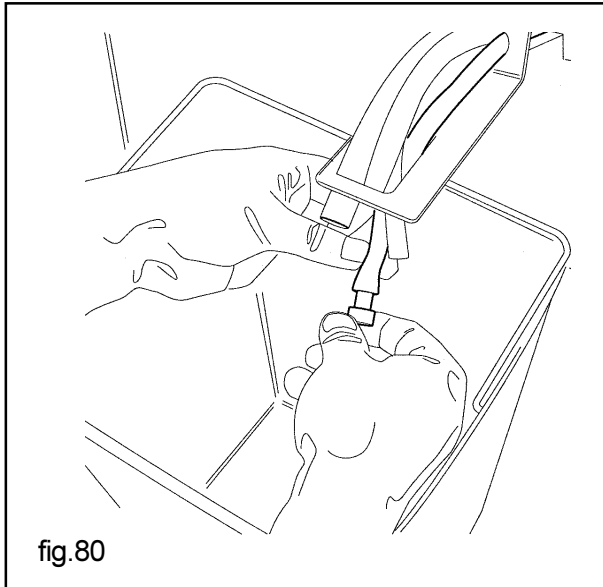

- unload all products from containers (fig.81)

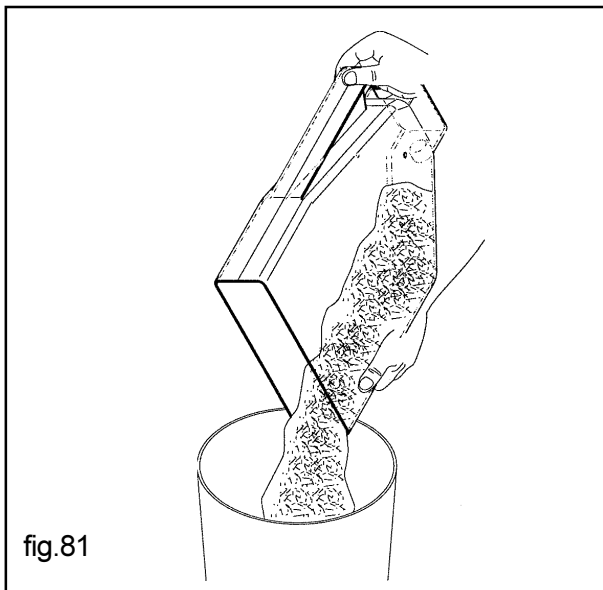

- take steps to clean all the parts in contact with foodstuffs according to the procedures already described;
- empty the liquid waste bin and clean it thoroughly;
- eliminate the coffee grounds bag;
- clean all the internal and external surfaces of the machine with a cloth;
- protect the outside of the machine with plastic film or a bag (fig.82);

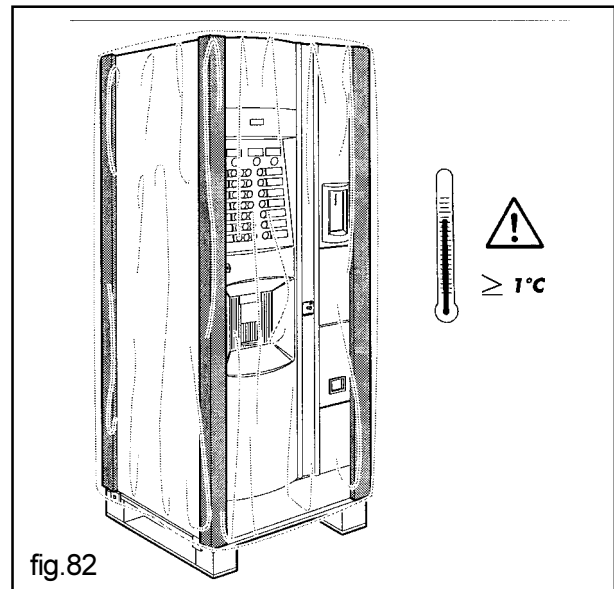

- store in a dry and sheltered place at temperatures of no lower than 1°C.

## **10 - DISMANTLING**

Start emptying the products and water as described in the previous paragraph. For the purpose of dismantling, you are advised to disassemble the machine dividing the parts according to their composition (plastic, metal etc).

Afterwards, deliver the subdivided parts to specialised companies. In the event of a cooling unit, deliver it without disassembling it to companies authorised for the disposal of this particular element.

## 11 - TROUBLESHOOTING GUIDE FOR THE MOST COMMON FAILURES OR ERRORS

In SERVICE mode, failures or faults, when present are immediately displayed in the follow manner:

Display message	Probable cause
<b>E01</b> - CUPS	<ul style="list-style-type: none"> <li>- Lack of cups</li> <li>- Cup presence microswitch failure</li> </ul>
<b>E02</b> - GRINDER	<ul style="list-style-type: none"> <li>- Lack of coffee</li> <li>- Grinder jammed</li> </ul>
<b>E03</b> - COFFEE GOUP	<ul style="list-style-type: none"> <li>- Unit motor jam</li> <li>- Motor position microswitch failure</li> </ul>
<b>E04</b> - ESPRES. PUNP	<ul style="list-style-type: none"> <li>- Pump failure</li> <li>- Coffee solenoid valve</li> <li>- Volume meter</li> </ul>
<b>E05</b> - INSTANT PUMP	<ul style="list-style-type: none"> <li>- Pump failure</li> <li>- Coffee/instant drink solenoid valve</li> </ul>
<b>E07</b> - SCALING	<ul style="list-style-type: none"> <li>- Error in scaling factor setting (standard money) in the coin box</li> </ul>
<b>E08</b> - LACK WATER	<ul style="list-style-type: none"> <li>- Lack of water</li> <li>- Liquid waste bin full</li> <li>- Chamber microswitch failure</li> </ul>
<b>E09</b> - EEPROM MEM.	<ul style="list-style-type: none"> <li>- EPROM failure</li> </ul>
<b>E11</b> - HEAT SENSOR	<ul style="list-style-type: none"> <li>- Coffee unit probe short circuited or interrupted</li> </ul>
<b>E12</b> - COF T<70°C	<ul style="list-style-type: none"> <li>- Coffee boiler not heated</li> </ul>
<b>E13</b> - INS. T<70°C	<ul style="list-style-type: none"> <li>- Instant drinks boiler not heated</li> </ul>
<b>E15</b> - CLOCK ERROR	<ul style="list-style-type: none"> <li>- Clock board malfunction</li> <li>- Programming error</li> </ul>
<b>E16</b> - VOLUME	<ul style="list-style-type: none"> <li>- Reduced water delivery capacity in hydraulic circuit</li> </ul>
<b>E17</b> - NECKS MOTOR	<ul style="list-style-type: none"> <li>- Nozzle motor failure</li> <li>- Motor position microswitch failure</li> </ul>
NO SERIAL CONNECTION	<ul style="list-style-type: none"> <li>- Waiting for/no connection with serial coin box</li> </ul>

The alarm E16- CAPACITY is a mere signal, which does not block the machine, but does indicate a progressive reduction of the water delivery in the pump-solenoid valve circuit or an inefficiency of the volume meter (small fan) or the presence of limescale deposit on the solenoid valves; this signal pre-announces an imminent failure E04-PUMP.

Other signals that do not block the machine are also foreseen and have the objective of advising the user that the regeneration of descaler resins, the grinders and filters is necessary.

The number of vends beyond which the regeneration is deemed necessary is set in the OPTIONS menu; the display messages anticipated are:

- \* to indicate the error E16 CAPACITY
- $\alpha$  to indicate the resin regeneration
- & to indicate the filter replacement
- \$ to indicate the grinder replacement
- # to indicate the replacement of filters and grinders
- % to indicate resin regeneration and grinder replacement
- $\Omega$  to indicate resin regeneration and filter replacement
- $\pi$  to indicate resin regeneration as well as filter and grinder replacement.

If one of the above mentioned symbols is displayed, by entering the SERVICE mode, the message ALARM will appear followed by the symbol for which maintenance is necessary.

JP1/JP2	= EXPANSION BOARD CONNECTION
JP3	= DISPLAY CONNECTOR
JP4	= KEYS EXPANSION
JP6	= POWER BOARD CONNECTOR
JP7	= COUNTER
JP8	= 24V VALIDATOR CONNECTOR
JP9	= OBLITERATOR CONNECTOR
J1	= PC PROGRAMMING CONNECTOR
J2	= DATA COLLATION CONNECTOR
J3	= SAECO ELECTRONIC KEY CONNECTOR
J4	= EXECUTIVE CONNECTOR (MASTER)
J5	= PUSHBUTTON PANEL CONNECTOR
J7	= 24V INPUT CONNECTOR
J8	= MDB CONNECTOR
J9	= EXECUTIVE CONNECTOR (SLAVE)
F2	= 4A FUSE
S1	= PROGRAMMING KEY
S2	= SERVICE KEY
LD1	= PAYMENT SYSTEMS SERIAL CONNECTION LED
LD2	= SUPPLY LED
JMP1	= JUMPER FOR COIN 7
JMP2	= JUMPER FOR COIN 8
TR1	= DISPLAY CONTRAST REGULATION
U1	= EPROM BASE
U2	= CLOCK BASE

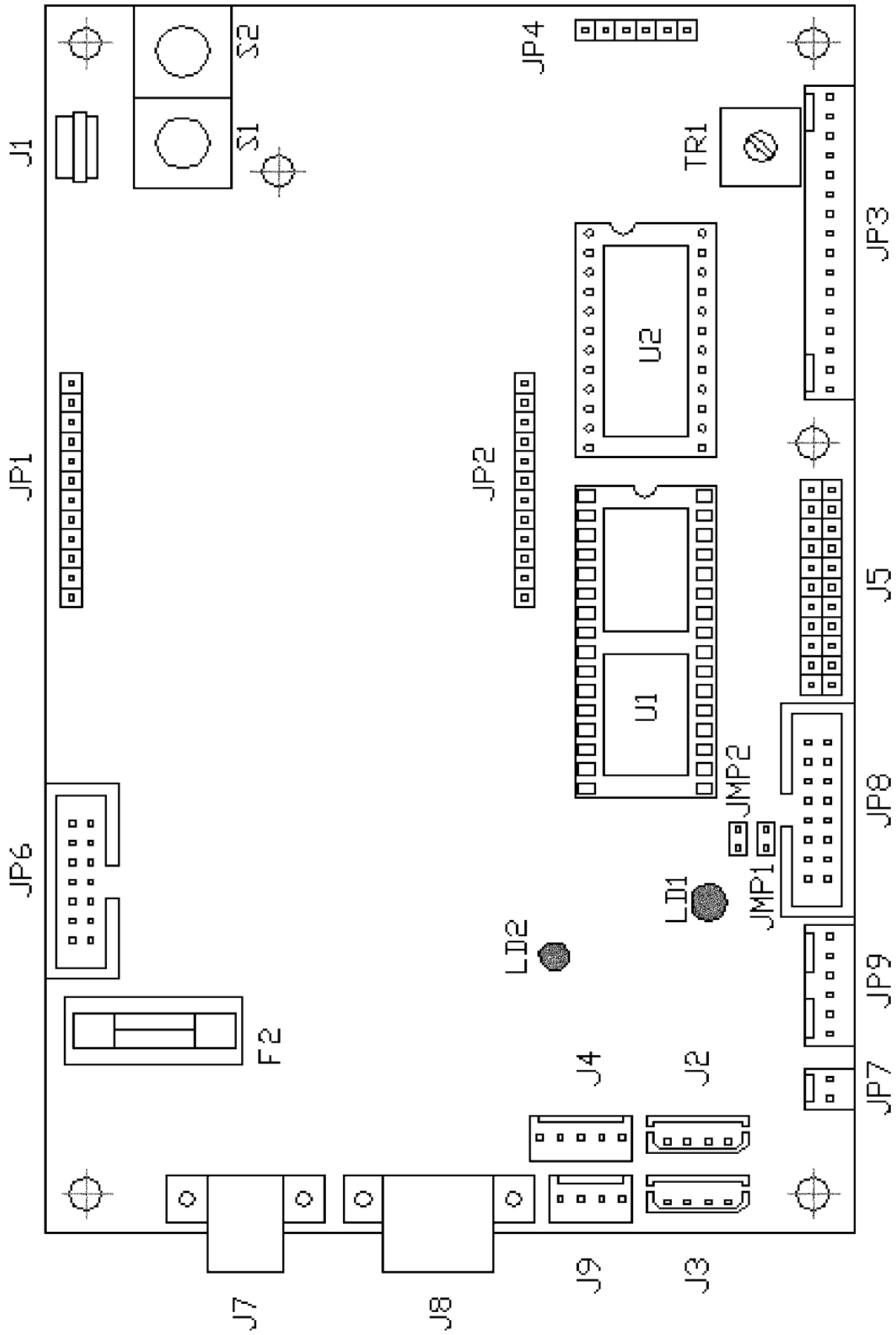

**Note:**

**Note:**

**Note:**

**Note:**

**Note:**

